



PROVIDENCE WATER

Tap Water Delivers

August 11, 2015

The Hon. Jorge O. Elorza
Mayor

Ricky Caruolo
General Manager

Mrs. Luly Massaro
Commission Clerk
RI Public Utilities Commission
89 Jefferson Boulevard
Warwick, RI 02888

BOARD OF DIRECTORS

Xaykham Khamsyvovong
Chairperson

Joseph D. Cataldi
Vice Chairperson

Michael J. Correia
Councilperson

Sabina Matos
Councilperson

Lawrence J. Mancini
Ex-Officio

Andy M. Andujar
Member

Kerri Lynn Thurber
Member

Carissa R. Richard
Secretary

William E. O'Gara, Esq.
Legal Advisor

RE: DK 4571-Bristol County Water Authority- Data Request Set 3

Dear Mrs. Massaro:

Enclosed please find an original and nine copies of Providence Water's responses to the third set of data requests from BCWA. Copies have been mailed to members of the service list who requested hard copies.

If there are any questions I can be reached at 521-6300, extension 7217.

Sincerely,

Mary L. Deignan-White
Senior Manager of Regulatory

cc: Dk 4571 Service List
File

MEMBER

Rhode Island Water Works Assn.
New England Water Works Assn.
American Water Works Assn.
Water Research Foundation

An EPA WaterSense Partner

(401) 521-6300

552 Academy Avenue
Providence, RI 02908

www.provwater.com

Follow us @provwater

Like us at:
facebook.com/Providencewater

s:\chalkall\regulato\dk xx abbr 2015\lm-bcwa_1_7215.dotx

PROVIDENCE WATER SUPPLY BOARD
Docket No. 4571

Data Requests of the
Bristol County Water Authority- Set 3
August 4, 2015

BCWA 3-1: In the past three years, how many fire hydrant deliveries have been made to Providence's Academy Avenue facility? Please provide the data for each such delivery.

RESPONSE:

There have been thirteen (13) deliveries from July 31, 2012 through July 31, 2015.

<u>Delivery Date</u>	<u>Quantity Shipped</u>
07/31/12	21
08/14/12	8
10/18/12	28
10/23/12	2
04/25/13	21
05/08/13	1
12/20/13	24
08/28/13	27
04/03/14	33
08/31/14	31
02/18/15	24
02/24/15	9
06/01/15	10

PROVIDENCE WATER SUPPLY BOARD
Docket No. 4571

Data Requests of the
Bristol County Water Authority- Set 3
August 4, 2015

BCWA 3-2: Mr. Giasson's testimony refers to two CDM studies included in Exhibit GG-1, but only the 2009 Phase II included. Please provide a copy of the Phase I CDM Report for inclusion in this Docket.

RESPONSE:

Please see the attached CDM Phase I report.

Providence
Water

Providence Water Supply Board Facility Assessment - Phase I

December 2008

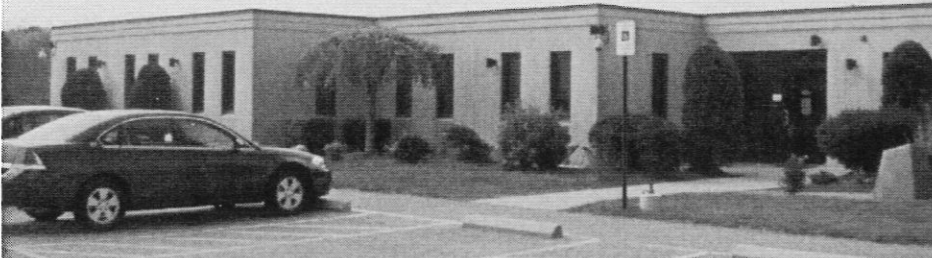

Final Report

CDM

Contents

Executive Summary

Section 1 - Project Understanding and Approach

1.1	Project Understanding	1-1
1.2	Project Approach	1-1
1.2.1	Phase I	1-1
1.2.2	Phase II	1-2

Section 2 - Facilities Assessments

2.1	Systems Reviewed	2-1
2.2	Assessment Methodology	2-1
2.3	Architectural	2-2
2.3.1	Cranston Facility	2-2
A.	Overall/External	2-2
B.	Interior	2-2
C.	Site	2-3
2.3.2	Academy Avenue Facility	2-3
A.	Overall/External	2-3
B.	Interior	2-5
C.	Site	2-6
2.4	Structural	2-6
2.4.1	Cranston Facility	2-6
A.	Overall	2-6
2.4.2	Academy Avenue Facility	2-7
A.	Overall	2-7
B.	Roof Deck	2-8
C.	Wood Framing	2-8
D.	Brick Walls	2-9
E.	Floor Slab	2-9
2.5	HVAC	2-10
2.5.1	Cranston facility	2-10
A.	Heating and Air Conditioning Systems	2-10
2.5.2	Academy Avenue Facility	2-11
A.	Boiler and Related Equipment	2-11
B.	Building Heating	2-12
C.	Air Conditioning Systems	2-13
D.	Garage Area Supply Air and Exhaust Systems	2-15

2.6	Plumbing and Fire Protection.....	2-16
2.6.1	Cranston facility	2-16
	A. Potable Water Supply from the City.....	2-16
	B. Fire Protection System	2-17
	C. Sanitary Sewer System.....	2-17
	D. Storm Water System.....	2-18
	E. Natural Gas System.....	2-18
2.6.2	Academy Avenue Facility	2-18
	A. Potable Water Supply from the City.....	2-18
	B. Fire Protection System	2-19
	C. Sanitary Sewer System.....	2-20
	D. Storm Water System.....	2-20
	E. Natural Gas System.....	2-21
2.7	Electrical.....	2-21
2.7.1	Cranston facility	2-21
	A. Service Entrance and Distribution System.....	2-21
	B. Building Lighting and Small Power Systems	2-22
	C. Building Fire Alarm System.....	2-22
	D. Building Telecommunication System.....	2-23
	E. Building Security System	2-23
2.7.2	Academy Avenue Facility	2-23
	A. Service Entrance and Distribution System.....	2-23
	B. Building Lighting and Small Power Systems	2-25
	C. Building Fire Alarm System.....	2-25
	D. Building Telecommunication System.....	2-25
	E. Building Security System	2-26
2.8	Costs	2-26
2.8.1	O&M Expenses	2-26
2.8.2	Repair Costs	2-27

Section 3 - Organization and Operations Assessment

3.1	Introduction.....	3-1
3.2	Questionnaire Process.....	3-1
3.3	Organizational Chart Review	3-1
3.4	Participants.....	3-2
3.5	Questionnaire and interview Response.....	3-2
3.5.1	Cranston Facility Comments	3-2
3.5.2	Academy Avenue Facility Comments.....	3-3

Section 4 - Needs Assessment

4.1 Program Data4-1
4.2 Facilities Sketches4-1

Section 5 - Summary

5.1 Summary.....5-1

Figures

4.1 Facilities Sketches4-11

Tables

4.1 Departmental Spaces4-2
4.2 Shared Facilities4-6
4.3 Vehicle Parking4-8
4.4 Site Size4-10

Appendices

Appendix A List of Program Data
Appendix B Facilities Assessment Photographs
Appendix C Sample Questionnaire

Executive Summary

The Providence Water Supply Board (PWSB) has retained CDM to complete an assessment of the Scituate Avenue (Cranston) and Academy Avenue (Providence) facilities. The purpose of this report is to assist the PWSB in gaining an understanding of the condition of the facilities, and how they impact day to day operations.

Under Phase I of the project, CDM's team of architects and engineers reviewed available on-site documentation and conducted a visual assessment of both facilities. This report documents our findings and recommendations based on the data available, our observations from the site visits, the results of our questionnaire and interview process, and the development of programming needs. The following key considerations have been identified through Phase I:

Cranston Facility:

- Additional space is needed for files, storage, lockers and showers, receiving, a dedicated computer room, and meetings.
- Efforts to accommodate growth and the need for storage have evolved into a less optimum use of floor space.

Academy Avenue:

- The single site entrance and access road is a safety hazard for visitors and employees, with PWSB vehicles and deliveries entering and leaving the site. Delays sometimes extend into Academy Avenue.
- Large trucks making deliveries to the central stock room or yard storage areas are not able to maneuver safely into the yard due to restricted aisles and turning space, and frequently must be unloaded by forklifts while parked on Academy Ave, resulting in a serious hazard to traffic and pedestrians.
- Parking for employees and PWSB vehicles in the yard is inadequate, and restricted aisle space has caused accidents and damage to vehicles.
- Storage and handling of bulk materials is limited, and maneuvering space for trucks and loaders is severely restricted.
- The site is too small to accommodate programmed needs for parking of employee, visitor, and PWSB vehicles.
- Building facilities components are approaching or beyond their useful service life, and the upgrades required to bring all components into compliance with current codes represents a substantial investment and rehabilitation program.

- A major capital investment for physical improvements to the building would not solve space congestion and functional deficiencies due to size and layout.
- The long term efficient operations of the PWSB would appear to be best served by relocating the Academy Avenue facility.

Phase II of the project is intended to include additional analysis and recommendations related to site configurations, potential combinations of departments at existing or new sites, market data evaluation to identify potential properties meeting the program needs, and additional reporting with implementation suggestions.

CDM would like to acknowledge the support and assistance provided throughout the project by Joe Spremulli, Gary Marino, Tony Araujo, and Jackie Brosco.

Section 1

Project Understanding and Approach

1.1 Project Understanding

The Providence Water Supply Board (PWSB) has implemented this project to develop a comprehensive assessment of its existing building facilities in Cranston and Providence. This assessment includes an evaluation of the physical conditions of the two buildings, as well as the identification of space needs for existing operations. The Providence location serves as the main office of the PWSB, and includes office space, customer service, all central communications and security systems, maintenance areas, parking for vehicles and equipment, plus storage of materials. The Cranston office houses Finance, Engineering, and members of the Support Services group, and is located adjacent to the aqueduct reservoir and pump station.

The goal of the project is to identify deficiencies and recommendations for the locations which will aide in long term efficient operations of the facilities. The work is divided into two separate phases, detailed below.

1.2 Project Approach

1.2.1 Phase I

The following items are included in Phase I of the project:

1. *Project Kickoff Meeting and Data Collection* - CDM met with PWSB to identify appropriate contact personnel. CDM also worked with PWSB to obtain and review copies of existing relevant information such as building and site. We also obtained from PWSB an organizational chart and listing of current staffing levels for each department. Also compiled was be a listing of vehicles, trailers, mobile equipment and accessories to be garaged and/or serviced at each site, including the size and fuel type for each. A list of data compiled during this process is included in Appendix A.
2. *Facility Assessments* - CDM visited the existing Providence and Cranston facilities to evaluate current physical and mechanical conditions, including architectural, structural, electrical, HVAC, and instrumentation. The process is described further in Section 2.
3. *Organization and Operations Assessment* - This evaluation includes interviews with PWSB staff to determine how current space is used and what space is required to effectively perform job functions. This process is described further in Section 3.
4. *Needs Assessment* - Resulting from the inspections and interviews, CDM has generated program documents including space requirements, identification of shared facilities, vehicle considerations, and recommended site size. This assessment is discussed further in Section 4.

5. *Phase I Report* – This document summarizes and presents the data generated in all Phase I tasks, including the facilities assessments, organizational analysis, and needs assessment. Phase II work is scheduled to commence following review of this document by PWSB.

1.2.2 Phase II

Following delivery and approval of the Phase I report, additional analysis and recommendations are to be developed in Phase II, including the following:

1. *Evaluation of Facilities Siting* - Given the deficiencies, needs, and costs identified in Phase I, CDM will evaluate several possible configurations and compare the existing facilities with new sites in various configurations
2. *Market Evaluation* -Working with our Real Estate Consultant, Hayes and Sherry, CDM will evaluate current real estate market conditions to identify cost effective options for the PWSB, including identification of existing properties and/or buildings that meet the requirements identified in Phase I, including square foot costs, future expansion and storage requirements, rehabilitation or reconstruction issues, and lease/purchase options.
3. *Phase II Report*- This final report will incorporate the recommended plan, cost/benefit discussion, and suggested implementation strategies to meet PWSB's goals.

Section 2

Facilities Assessments

CDM's team of architects and engineers performed site inspections on Tuesday May 20th, 2008. The work included a review of the available building documents, and visual reviews of major facility elements and systems. This review of the buildings and systems was executed by representatives of various building trades including Architectural, Structural, HVAC, Plumbing, and Electrical. The team spent considerable time with Messrs. Joe Spremulli, Gary Marino, and Tony Araujo of PWSB gaining a more detailed understanding of the facilities. Select photographs obtained during the inspections are included in Appendix B.

2.1 Systems Reviewed

As noted, the following five major building systems were reviewed:

1. *Architectural* – The architectural review assessed the structural building components, exterior shell systems such as walls, doors, windows, louvers, vertical circulation, etc. This review identified building modification necessary to meet the most recent building codes and design standards.
2. *Structural* – The Structural review assessed the structural building components, exterior shell systems such as walls, canopies, support systems, roofing, interiors, and floor systems.
3. *HVAC* – The HVAC review assessed the boilers, building heating, cooling, air handling units, compressors, exhausts, and computer room and controls, as required.
4. *Plumbing and Fire Protection* – The Plumbing and Fire Protection review assessed the potable water supply, fire protection, sanitary sewer, stormwater, fuel oil, and natural gas systems.
5. *Electrical* – The electrical review assessed the service entrance, emergency generator, building lighting, power distribution, fire alarm, telecom, and security systems.

2.2 Assessment Methodology

The approach to the assessment generally breaks each system into categorical information including the following:

1. *Description* – Provides a brief description of the system and its components.
2. *Available Data* – Identifies the data that was available on site or in the documentation that was utilized in gaining background information about the system.

3. **Source Age and Capacity** – This information is gleaned from the available data identifying the utility source for the system (if applicable), age of the components and their original capacity.
4. **Condition** – Documents our opinion of the condition of the system. This opinion is only based on the data made available, and the information that could be gained from the visual review of the building.
5. **Recommendation** – Included are recommendations for addressing concerns that may be detrimental to the life of the system, capacity or risk to safety of the operating personnel or the public. The recommendations will either re-establish or enhance the system performance, save operating costs, or bring the system up to current codes and standards after implementation

2.3 Architectural

2.3.1 Cranston Facility

A. Overall/External

The Cranston, RI Facility is a 10 year old, one story, 12,625 gross sq. ft. building comprised of modular prefabricated units installed on a permanent concrete foundation. The exterior wall is constructed of wood framing with an exterior facing of rigid insulation coated with synthetic plaster (aka EIFS); the interior is painted gypsum board with resilient base. Exterior windows are anodized bronze finish aluminum casement type with insulating glass. Doors are anodized bronze finish aluminum. Roofing is a single ply rubber material, ethylene propylene diene monomer (EPDM), mechanically attached to the substrate of tapered rigid insulation over a plywood roof deck. The insulation provides pitch to depressions around roof drains connected to an interior piping system. An aluminum fascia acts as termination of the membrane at the building perimeter. Several roof-mounted pieces of mechanical equipment and skylights are located on curbs on the roof surface which are tied into the roofing system with membrane flashing.

<u>Exterior Building System:</u>	<u>Condition Assessment:</u>
Exterior wall (EIFS)	Good
Windows	Good
Doors	Good
Roofing	Good, some "ponding" of rain water

B. Interior

The interior of the building accommodates office functions and support spaces for several departments of the PWSB. Floors are steel framed with oriented strand board wood subfloor and are carpeted in the general office area, with resilient tile in toilets, lunch room and utility spaces. Ceilings throughout are 4-foot by 4-foot, lay-in acoustical tile, suspended with an exposed painted metal tee system. Lighting fixtures are 2-foot by 4-foot, fluorescent with prism lens. Walls are gypsum board, generally painted but

with a variety of finishes depending on location, with a resilient wall base. Some partitions consist of a prefabricated removable gypsum panel system with vinyl wall covering. Interior doors have painted steel frames with natural oak veneer wood doors. A moveable modular furniture and partition system is used throughout the building for staff workstation cubicles. It is comprised of painted metal framing with fabric covered acoustical panel infill, laminate worktops, painted shelving and storage bins supported by the partitions, and mobile file/drawer units below worktops. The break room has wood base and wall cabinets with laminate countertop. Toilet partitions are painted metal.

<u>Interior Building System:</u>	<u>Condition Assessment:</u>
Carpet	Fair
Resilient flooring	Good
Ceiling system	Good
Gypsum board walls	Good
Gypsum partition system	Good
Doors and hardware	Good
Modular furniture system	Good
Kitchen cabinets	Good
Toilet partitions	Fair

C. Site

The office building is located on a large open site, set back approximately 350-feet southwest from Scituate Avenue, and abuts the earth-covered aqueduct water storage reservoir on the southwest side. The site is fenced with an access road and gated entrance off Scituate Avenue. Visitor parking for 15 cars, with 4 spaces reserved for handicapped, is located on the entrance side of the building facing Scituate Ave. The access road leads to a 102 car employee parking area behind the building. Roads, parking and walkways are asphalt paved. The building is occupied by the Finance, Purchasing and Engineering Departments.

2.3.2 Academy Avenue Facility

A. Overall/External

The Academy Avenue facility is reportedly a late 19th to early 20th century building, originally constructed as a trolley barn. The building is located on a 120,000 sq. ft. (2.75 acre) site. The high bay garage and shop area is bordered along the street (east) side by a two story strip of space, housing offices and support functions. In 1953, a two story addition was constructed along the (south) end of the building and is used as office space.

Gross floor area is as follows:

First floor high bay space (orig. building)	27,950 sq. ft.
First floor support space (orig. building)	4,000

First floor (1953 addition)	3,780
Second floor (orig. building)	4,000
Second floor (1953 addition)	3,780
Total gross area first floor	35,730
Total gross area second floor	<u>7,780</u>
Total gross area building	43,510 sq. ft.

The original building was constructed of heavy timber framing arranged in 20-foot by 24-foot bays. Timber beams are supported on columns and by solid brick bearing walls at the perimeter, and by a dividing wall between the garage and two story sections of the building. Exterior walls extend 4-6 feet above the roof surface and are capped with a clay tile coping. The second floor and roof are heavy wood decking spanning between timber beams. The roof structure is sloped to two longitudinal valleys for drainage to roof drains served by an interior piping system. The roof membrane is EPDM, which appears to be placed over rigid insulation and mechanically fastened to the roof deck. Several pieces of mechanical equipment and skylights are mounted on roof curbs and flashed with neoprene into the roof membrane. The perimeter of the membrane is turned up the parapet wall with neoprene base flashing, lapped and terminated behind copper counterflashing. Vertically hung multi-pane single glazed aluminum windows are integrated with aluminum curtain wall panels in two story arched masonry openings on the Academy Ave. street side. On the north smaller windows of the same type exist, covered with wire mesh security screens. New storefront aluminum framed window with insulating glass have been installed on the west side facing the parking area. Two large aluminum sectional overhead lift doors provide vehicle access to the garage space.

The 1953 addition is of similar construction, brick and limestone exterior walls, EPDM roofing membrane and multi-pane aluminum windows with granite sills.

<u>Exterior Building System:</u>	<u>Condition Assessment:</u>
Masonry walls	Good physical condition but uninsulated at garage and its support spaces, minor spalling of brick at exterior, pointing of masonry at back of parapet and tile coping needed
Windows (multi-pane)	Poor, inoperable or difficult to operate, energy inefficient single pane, no thermal break frames with deteriorated weather stripping, mill finish aluminum corroded
Windows (storefront)	Good, new insulating glass, anodized aluminum frames
Service doors	Fair, light duty, uninsulated
Personnel doors	Fair
Roofing system	Fair, some membrane fasteners not seated properly, counterflashing in poor condition

B. Interior

The high bay space is devoted to the garage, shops and storage spaces of the Transmission and Distribution Division. The interior of this area is basic painted timber framing, roof decking and masonry walls and painted concrete floors. Spaces are partitioned with light wood framed walls of painted plywood and chain link fencing. Offices adjoining the garage have pre-finished oak veneer plywood paneled walls, 2-foot x 4-foot acoustical tile ceilings, painted concrete floors, hollow core wood doors and wood frames. Toilet rooms have terrazzo floors, tile wainscoting on painted brick walls and painted plaster ceilings. Employee lockers are painted steel and located in the garage space. Truck bodies stored in the garage are used as storage containers.

<u>Interior Finishes Garage Area:</u>	<u>Condition Assessment:</u>
Wood columns	Poor/Fair, damaged and covered with steel channels
Roof deck	Poor, peeling paint in many areas, some water damage by past roof leaks
Concrete floor finish	Fair, worn paint, cracks, misalignment
Masonry wall finish	Fair, soiled by age and exposure
Partitions, painted	Fair, worn, soiled by age and exposure, not dust tight at electronic equipment room
Partitions, paneled	Fair, residential quality
Doors	Fair, functional residential quality
Terrazzo floors	Fair, need refinishing
Tile wainscoting	Good, selective regrouting needed
Acoustical tile ceilings	Fair, misaligned and some damage
Painted plaster ceilings	Fair
Lockers	Poor

The office areas of the building are occupied by the Administration, Commercial Services, MIS, and Support Services Departments. The general public is received in the customer service entrance vestibule at the ground floor, where bills may be paid at windows attended by staff of the Commercial Services Department. Office areas are located on the ground floor and second floor of the building. They are accessed by single loaded corridors extending most of the length of two sides of the building. Ceilings are suspended acoustical tile, either 1-foot x 1-foot concealed spline with 1-foot x 4-foot recessed fluorescent parabolic lens light fixtures and surface or pendant mounted 1-foot x 4-foot plastic lens fixtures, or 2-foot x 4-foot exposed painted metal tee system with recessed 2-foot x 4-foot fluorescent fixtures with prismatic lens. Walls are painted gypsum board, or painted brick, with a resilient wall base. Interior doors have painted steel frames with natural birch veneer or painted wood doors. A moveable modular furniture and partition system is used throughout the building for staff workstation cubicles. It is comprised of painted metal framing with fabric covered acoustical panel infill, laminate worktops and painted shelving, storage bins supported by the partitions, and mobile file/drawer units below worktops. The break room has wood base and wall cabinets with laminate countertop. Toilet partitions are painted

metal. Floors are carpeted in the general office area, resilient tile in toilets, lunch room, workrooms and utility spaces. The Academy Avenue entrance area has terrazzo floor and marbled wainscoting.

<u>Interior Building System:</u>	<u>Condition Assessment:</u>
Carpet	Fair
Resilient flooring	Good
Ceiling system	Fair
Gypsum board walls	Fair
Doors and hardware	Fair
Modular furniture system	Fair
Kitchen cabinets	Good
Toilet partitions	Fair

C. Site

This facility is located on an urban site in a residential neighborhood of Providence. The property is bordered on the north and west by the LaSalle Academy School buildings, playing fields and parking, on the south by 1 and 2-story residences, and fronts directly on Academy Avenue to the east. Across the street are residences. The site is fenced with an access road and gated entrance off Academy Avenue on the south side of the building. On the north side of the access road is visitor parking for 9 cars, including 2 handicapped spaces, and the customer service building entrance. The access road leads to a 1.78 Acre paved yard occupying all the property west of the building. The yard contains parking for PWSB and employee vehicles, a fueling facility with pumps and above ground tank, covered storage for crushed stone and graded fill, excavated soil and cold patch, storage shed, several waste dumpsters and cribs, plus open and fenced storage for piping, road plates, barrels, etc. Materials handling areas are separated by concrete block barriers. Roads, parking and walkways are asphalt paved.

2.4 Structural

2.4.1 Cranston Facility

A. Overall

- **Description** – The building is a one story structure constructed of pre-engineered modular units. The overall plan dimensions are about 156' x 90'. The roof of the building is approximately flat but sloped slightly for drainage. It is constructed of a wood deck supported by wood framing. The floor of the building is also a wood deck. The floor is supported by light gage steel framing. The steel framing consists of 8" and 12" beams supported by a cast-in-place concrete foundation. The foundation consists of 24" diameter concrete piers and a perimeter concrete wall constructed in a 3' crawl space below the floor .
- **Available Data** – Data for this report was taken from original construction drawings by Beta Engineering, Inc, July 1997, supplemented by information obtained during a site inspection by CDM engineers.

- **Age** – The building is about 10 years old.
- **Condition** – The overall condition of the building is good. The steel beams supporting the floor, although slightly rusted, are in good condition. The concrete foundation, the piers and perimeter wall, are in good condition.
- **Code Issue** – The building code requires, if an addition or alteration is added to an existing building, the entire seismic-force-resisting system of the building may need to conform to the design requirements of a new structure. This means if significant changes are planned for this facility it will probably trigger a requirement to analyze the building for seismic loads.
- **Recommendations** – If it is decided to alter the building or change its use a feasibility study should be performed based upon the building code issue that may require reinforcing the entire building for seismic load requirements for a new building. The feasibility study would determine, if reinforcing the building is required and if it is practical and reasonable.

2.4.2 Academy Avenue Facility

A. Overall

Description – The building was converted from an old trolley barn to a garage and office building years ago. Around 1953 an addition was added on the south side. The building is a one story structure in the garage area and two stories in the office area. Overall plan dimensions are about 252-feet x 144-feet. The roof of the building is constructed of a wood roof deck and wood beams. The beams are supported by the exterior and interior brick walls and wood columns. The first floor is a slab-on-grade.

- **Available Data** – Original construction drawings are not available. Several architectural drawings exist for the addition and alterations in August 1953.
- **Age** – The building was reportedly constructed before 1900. The addition was added around 1953.
- **Condition** – The building is very old and in fair condition. The roof deck looks good. The wood roof beams have been reinforced. Some columns have been damaged and reinforced. The brick walls look good, but because of age, the strength of the walls is questionable. The floor is cracked and voids exist beneath the floor.
- **Code Issue** – The building code requires, if an addition or alteration is added to an existing building, the entire seismic-force-resisting system of the building may need to conform to the design requirements of a new structure. This means if significant changes are planned for this facility, it will probably trigger a requirement to analyze and reinforce the building for seismic loads. This may not be practical or reasonable and the construction cost would probably be prohibitive.

- *Recommendations* – If it is decided to alter the building or change its use a feasibility study should be performed based upon the building code issue that may require reinforcing the building for seismic loads. The feasibility study would determine, if reinforcing the building is required and if it is practical and reasonable.

B. Roof Deck

- *Description* – The roof deck is constructed of 2-1/2" wood planks, tongue and groove. The deck is supported on wood beams.
- *Available Data* – Original construction drawings are not available. Information on the roof was obtained during the site inspection.
- *Age* – The original roof deck was constructed before 1900. The roof deck of the addition was constructed around 1953.
- *Condition* – The roof deck appears to be in good condition.
- *Drainage Issue* – There appears to be adequate roof drains. However, there is no secondary roof drainage system. In case the primary drains are blocked, there is no alternate drainage for the water. The code requires alternate drains to ensure water will not collect on the roof and overload the roof deck and its supports.
- *Recommendations* – A secondary roof drainage system should be added. One option is to install openings in the parapet.

C. Wood Framing

- *Description* – The original roof deck is supported by wood framing, beams and girders. The framing is supported on the exterior and interior brick walls and wood columns. Wood beams are 9-1/2" wide x 13-1/2" deep. Girders are 13" wide x 15-1/2" deep.
- *Available Data* – Original construction drawings are not available. Information on the wood framing was obtained during the site inspection.
- *Age* – The original roof deck was constructed before 1900. The roof deck of the addition was constructed around 1953.
- *Condition* – The wood beams have been reinforced in many locations. Reinforcing consists of additional timbers fastened on each side of the beams. The reason for the reinforcing is unknown unless it was to support the snow load required by the building codes since this building was originally constructed. Refer to the "Snow Load Issue" below. Two of the wood columns were noted as previously damaged. One has been reinforced with steel sections and plates, and the other was replaced with a steel tube. The wood framing is in fair condition.

- **Snow Load Issue** – The top of the brick parapet is as much as 6 feet above the low point of the roof. This leads to heavy snow loads from drifting snow. Calculations indicate beams and girders will be overstressed due to code recommended snow loads.
- **Recommendations** – The beams close to the parapet should be reinforced for increased snow loads due to drifting snow. Wood columns are subject to damage caused by vehicle operations in the garage area. The columns should be replaced or reinforced for protection.

D. Brick Walls

- **Description** – The exterior and interior brick walls support the roof beams and girders. The walls on the east and west sides of the garage are typical. They are 16" wide and constructed of clay bricks and mortar. They are unreinforced.
- **Available Data** – Original construction drawings are not available. Information on the brick walls was obtained during the site inspection.
- **Age** – The original building including the brick walls was constructed before 1900. The brick walls of the addition were constructed around 1953.
- **Condition** – The brick walls have been modified at some locations throughout the facility, but essentially they are intact. The mortar joints between the bricks have been repointed. However, repointing only addresses the exterior surface of the joint, and may actually covers up a poor interior joint condition. These walls are old and the interior condition of the brick and mortar is questionable.
- **Recommendations** – The strength of the brick walls may have deteriorated through the years. This is not unusual. Water penetrating into the wall, freezing and thawing will cause the brick and mortar to break down. If alterations to the building are made, the interior of the brick walls should be investigated. Cores of the walls should be taken to determine the interior condition of the brick and mortar.

E. Floor Slab

- **Description** – The first floor of the building is a concrete slab-on-grade. The thickness and reinforcing, if any, is unknown.
- **Available Data** – Original construction drawings are not available. Information on the floor slab was obtained during the site inspection.
- **Age** – The original building was constructed before 1900. Reportedly, there were pits within the floor for performing maintenance on the underside of the trolleys. The floor has been since modified. The maintenance pits no longer exist. When the modifications occurred is unknown. The first floor in the addition was probably constructed when the addition was constructed around 1953.

- **Condition** – The floor is cracked in many locations. Reportedly, voids beneath the floor were filled at least at one location when the floor cracked and failed. Soundings performed during a site inspection revealed hollows beneath the floor in an area approximately 3-feet wide x 80-feet long. The condition of the floor is poor to fair.
- **Recommendations** – Repairing the floor is not an emergency, but if alterations are planned for the building, the floor should be repaired at that time. Floor repairs would include removing the floor locally in the area of the voids, compacting the sub grade, filling the void with compacted soil or concrete, and replacing the floor.

2.5 HVAC

2.5.1 Cranston Facility

A. Heating and Air Conditioning Systems

- **Description** – Consistent with the modular design of this building, the heating, ventilation and air conditioning systems are also configured in a modular arrangement. The South, East and West perimeter walls are served as separate zones using a total of 4 units; with the south wall requiring 2 units due to its length. The remaining 6 units are arranged to distribute air mostly to interior open plan office areas, with the zones running generally from the rear to the front of the building.
- **Available Data** – Site plan information was taken from Drawing Number C-1, Site Plan, Modular Office Building, Preliminary, Dated July 2, 1997 prepared by Beta Engineering, Inc. The interior office layout is generally as shown on the floor plan prepared by Rhode Island Prison Industries dated March 25, 1997 with revisions 1 through 6. Also provided was an 8.5" x 11" reflected ceiling plan sketch showing approximate layout of ceiling diffusers, ductwork, and locations for rooftop HVAC units 1 through 10.
- **Source Age and Capacity** –
 1. Quantity of ten roof-top packaged gas-fired heat with electric air conditioning units. York Sunline 2000 Units, 3 tons nominal capacity each. Equipped with 30% outdoor air intake hoods for ventilation.
 2. Quantity of three Ductless Split System air conditioning units with indoor evaporator units and outdoor condenser units. Two condenser units are roof mounted and one is grade mounted. These units serve: the storage room currently used for security equipment; the main computer room including telephone distribution equipment; and the GIS computer room which is a new unit near the front of the building.
 3. Miscellaneous Area Exhaust Fans for toilets and conference rooms

■ *Condition* –

1. A sample inspection of nameplate information indicates the ten air conditioning units were manufactured in 1997, so these units are original. A brief visual roof inspection did not reveal any units which appear to have been replaced so it is assumed all equipment is original.
2. The ductless split system air conditioning units serving the main computer room and security room at the rear of the building also appear original. Nameplates were not inspected for detailed information.
3. The ductless split system serving the GIS computer room at the front of the building appears new and recently installed.

■ *Recommendations* –

1. The median service life estimate for packaged rooftop equipment is about fifteen years; most of these existing units should have several more years of remaining useful life.
2. As units are identified for replacement, the Owner should consider upgrading to higher efficiency equipment and consider the implementation of energy efficient operating strategies to reduce operating costs. This might include the use of outdoor air economizer cooling strategies to avoid the use of electric cooling when outdoor air conditions are favorable.
3. Building areas which consistently operate at uncomfortable temperatures should be further reviewed to determine the cause.
4. Systems should be periodically tested and rebalanced to ensure air flow rates and unit performances are within acceptable limits.

2.5.2 Academy Avenue Facility

A. Boiler and Related Equipment

- *Description* – The boiler is a cast iron sectional type with steam distribution throughout the facility. It is able to operate on either natural gas or No. 2 fuel oil. The boiler has been operating exclusively on natural gas for the past three heating seasons. The system is equipped with a duplex pump boiler feed unit to handle condensate return and boiler makeup water requirements.
- *Available Data* – 1953 Additions & Alterations to Administration & Operations Buildin, plans supplemented by field data collection.
- *Source Age and Capacity* –
 1. Weil-McClain Series 88 Size 1288. Capacity: 3000 MBH (thousand btu per hour) Gross Output; 2329 MBH Steam Net Output.

2. Burner: Webster Cyclonic: Gas - 3753 MBH max, 1850 MBH min; Oil 26 gph (gallons per hour) max, 15 gph min. Model JB2C-15-EP170-M.20-MP-UL. Serial No. U51172A-01-1097.
3. Boiler Feed Unit: MECO 9531. Capacity data not available.
4. From the serial number on the burner, this equipment is estimated to have been installed in 1997 or 1998, and is approximately 10 years old.

■ *Condition -*

1. Boiler and burner appear to be in relatively good condition with no major problems observed. With routine maintenance and inspection, this boiler and burner should provide reliable operation for another 10 years at a minimum.
2. Boiler feed pumps were noisy when operating, and the receiver tank was rusted on the exterior.

■ *Recommendations -*

1. Boiler was cycling on while outdoor temperatures were in the 60's, and operations personnel stated the boiler should be off. Controls should be checked for correct outdoor lockout temperature. Office areas in certain portions of the building were very warm.
2. Boiler feed pumps should be inspected for condition and reliability. The receiver should be inspected for internal corrosion

B. Building Heating

- *Description -* The building heating system consists of multiple zones of steam based heating equipment, with the type of heating terminal units depending upon the type of space being served. Office areas are served by perimeter finned tube radiation. The garage spaces, storage areas and related non office areas are primarily served by suspended fan forced flow steam unit heaters. The building is separated into zones with thermostatically operated control valves on the steam piping serving each of the major perimeter office spaces on the first and second floors. Steam unit heaters serving work and storage areas are controlled by local thermostats which cycle the unit heater fan as required to maintain space temperatures at the thermostat setting.
- *Available Data -* 1953 Additions & Alterations to Administration & Operations Building supplemented by field data collection.
- *Source Age and Capacity -*
 1. Most of the steam and condensate piping appears to date back to the 1953 building renovation, although there have been substantial portions of piping replaced since that time.

2. Age of the existing office area finned tube radiation is unknown.
3. Many work area units heaters appear to have been replaced at different intervals although some units may be original. Not all equipment was inspected in detail.

■ *Condition -*

1. Steam piping appears generally serviceable although reportedly covered with asbestos insulation, which makes maintenance and repair operations expensive and difficult.
2. Steam condensate piping is beginning to develop leaks with increasing frequency, especially in areas where piping is buried within concrete walls and subject to both internal and external corrosion.
3. The finned tube radiation age is unknown but appears to be in acceptable operating condition. Because this is thin wall piping, it is subject to developing leaks with increasing frequency. Thermostatically operated steam control valves have been failing frequently and require replacement.
4. Unit heaters appear operable based upon visible inspection. Units were not operating at the time of inspection. PWSB staff indicates adequate heating capacity is available with the current heating and ventilation arrangement.

■ *Recommendations -*

1. Any steam and condensate piping which is part of the original 1953 installation is well beyond its normally expected service life, and the occurrence of system leaks should be expected with increasing frequency. This piping should be scheduled for replacement. Any piping replaced during the 1997 upgrade work should provide reliable service for at least another 5 to 10 years.
2. Heating system control valves and thermostats should be inspected and considered for replacement if older than 20 years.

C. Air Conditioning Systems

- *Description -* Four packaged rooftop cooling air conditioning units serve the office areas on the East and South sides of the building. Supply and return air ducts from these units penetrate the roof above the garage and equipment storage area and then pass through interior partition walls to enter the ceiling spaces for the office areas they serve. Several smaller split system air conditioners serve local cooling needs. The main air handling units are configured for cooling only and do not contain any heating capability. Heating is provided by the perimeter steam radiation.

- **Available Data** – Field data collection. Plans showing these units were not available during inspection.
- **Source Age and Capacity** –
 1. Nameplate data indicates units manufactured in 1997.
 2. One 15-ton unit serves the customer billing area and related offices of the 1953 addition.
 3. One 20-ton unit serves the second floor space of the 1953 addition.
 4. One 15-ton unit serves the lower level offices and support spaces on the east side of the building facing Academy Avenue
 5. One 20-ton unit serves the second floor offices along the second floor east side of the building.
 6. One split system air conditioner serves the 2nd floor security room, and a second unit serves the mezzanine office space in the northeast corner of the garage and equipment storage area.
- **Condition** –
 1. Air conditioning units appear in acceptable condition, although they were not operating during the inspection. Internal inspection was not performed.
 2. Supply and return air ductwork passing through the garage air does not appear to be sealed. The unsealed return air ductwork operates under a negative pressure, and is subject to leakage of vehicle exhaust fumes when engines are operating in the garage area.
- **Recommendations** –
 1. The median service life estimate for packaged rooftop equipment is about 15 years so most of these existing units should have at least several more years of remaining useful life.
 2. Air conditioning units do not operate continuously, so ventilation air circulation is not continuous in the space. A continuous circulation of return and outdoor air is generally recommended for occupied spaces, and is required by current code if windows are not operable. Continuous introduction of outdoor air to the occupied spaces would also reduce the tendency for engine exhaust fumes to infiltrate into the office areas from the garage and equipment storage area.
 3. Seal the transverse and longitudinal joints on all air conditioning return air ductwork located in the garage area to reduce tendency for air infiltration into the office spaces.

4. Systems should be periodically tested and rebalanced to ensure air flow rates and unit performances are within acceptable limits.
5. As units are identified for replacement the Owner should consider upgrading to higher efficiency equipment and consider the implementation of energy efficient operating strategies to reduce operating costs. This might include the use of outdoor air economizer cooling strategies to avoid the use of electric cooling when outdoor air conditions are favorable.
6. Building areas which consistently operate at uncomfortable temperatures should be further reviewed to determine the cause.

D. Garage Area Supply Air and Exhaust Systems

■ *Description -*

1. 1953 drawings show primary roof exhaust fans serving the garage area. The northern most roof exhaust fan is still installed on the roof but is out of service. Its duty is now served by a propeller wall exhaust fan installed in the north wall of the garage area.
2. Two Carbon Monoxide exhaust collection systems are also installed and equipped with lengths of flexible hose for local exhaust pickup at points where vehicles may be operating indoors. These require an operator to attach the exhaust hose to the tailpipe or exhaust stack of the idling vehicle to reduce the levels of tailpipe emissions in the garage.
3. There were no supply air ventilation systems installed to serve the garage.

■ *Available Data -* 1953 Additions & Alterations to Administration & Operations Building supplemented by field data collection.

■ *Source Age and Capacity -*

1. Two active roof exhaust fans are rated at 7500 cfm each. These appear to date back to 1953 and are in poor condition.
2. The propeller exhaust fan mounted in the north wall appears more recent and in operable condition, although it was not running during the inspection.
3. The two carbon monoxide exhaust systems appear relatively new and in operable condition. Capacity information was not available; however, system duct and flexible hose diameters appear marginal for the type and size of equipment being stored in the facility. Roof mounted exhaust fans flow and pressure capacities also appear undersized for this type of service.

■ *Condition -*

1. See source age and capacity for comments on equipment condition.

■ **Recommendations -**

1. Large area type roof exhaust fans should be replaced with new equipment.
2. Carbon monoxide exhaust systems should be evaluated for adequate flow and pressure capacity appropriate for the required service and modifications made as required for acceptable performance.
3. Current codes require maintenance and service garages be continuously ventilated with outdoor air; there is currently no equipment installed to provide this ventilation.
4. All occupied spaces adjoining the garage and equipment storage area should be provided with continuous outdoor air ventilation to reduce the tendency for vehicle exhaust emissions to migrate into these areas.
5. Carbon monoxide and Nitrogen Oxide monitoring should be installed in the garage area to operate incremental ventilation automatically based upon elevated levels of vehicle emissions.

2.6 Plumbing and Fire Protection

2.6.1 Cranston Facility

A. Potable Water Supply from the City

- **Description** - Potable water supply piping enters the site as ductile iron pipe and then transitions to copper piping system for distribution. It is protected through a backflow preventer.
- **Available Data** - Backflow testing does not appear to be up to date, evidenced by a lack of up-to-date backflow testing certificates. During the site visit PWSB staff noted that the domestic service backflow preventer was replaced about three months ago.
- **Source Age and Capacity** - Potable water supply consists of water service with a backflow preventer. The copper piping water distribution system is only 10 years old and feeds the men's and women's restroom, a slop sink, electric water cooler and some wall hydrants on the outside of the building.
- **Condition** - Water piping is in "Good" condition. The piping should be insulated with 1 inch thick insulation for energy efficiency and to prevent anyone from getting burned from the water supply.
- **Recommendations** - Conduct required backflow testing and maintain records of when the testing was done. The newly installed backflow preventer is very close to the wall, and may have to be moved away from the wall so that maintenance can be performed on the unit in the future, in accordance with the local plumbing code. The water piping serving the handicapped lavatories needs insulation to protect against injury to someone using a wheelchair. All water

piping should be insulated and labeled. The exterior hose bibs have built in backflow preventers; therefore, there does not appear to be any cross connections in the building.

B. Fire Protection System

- *Description* – Fire protection is ductile iron pipe at entrance to the site and then transitions to black steel for the distribution system.
- *Available Data* – Fire protection inspections are not up to date and lack backflow testing certificates.
- *Source Age and Capacity* – Similar to the domestic water system the fire protection distribution system is only 10 years old. Capacity and source age of the fire protection system are fine.
- *Condition* – Fire protection system is in very good condition. Sprinkler layouts in the building appear to be adequate and are in conformance with the code.
- *Recommendations* – The fire protection system appears to be well laid out and in conformance with code. Maintain records of when the system is tested annually and make sure that the double check valve is maintained in accordance with local standards. The piping should be labeled.

C. Sanitary Sewer System

- *Description* – Sanitary sewer system consists of PVC pipe throughout. The piping is visible from the 2-1/2 foot crawl space that was accessed in the Maintenance Room
- *Available Data* – Installed ten years ago, the entire sanitary piping system consists of PVC piping
- *Source Age and Capacity* – The sanitary piping was installed new ten years ago when the modular structure was erected. The piping was sized with plenty of capacity to handle the flow from the two restrooms and service sink and electric water cooler located adjacent to the restrooms.
- *Condition* – The condition of the PVC piping appears to be in very good condition. The piping is bowed a little bit in the crawl space due to lack of support, but that can be easily addressed through the installation of additional supports.
- *Recommendations* – The sanitary PVC piping is in very good condition and is only ten years old. The piping in the crawl space needs additional support, as some of the piping is sagging between the supports and the piping is developing a slight bow. The piping should also be labeled.

D. Storm Water System

- *Description* – Storm water piping consists of PVC. The piping system was installed only ten years ago when the modular building was erected.
- *Available Data* – As mentioned above the piping was installed new only ten years ago when the building was erected.
- *Source Age and Capacity* – The piping material is PVC and was installed ten years ago. The roofing is well pitched and the piping appears to be sized accordingly.
- *Condition* – The PVC piping is in very good condition.
- *Recommendations* – The PVC is in very good condition and appears to be sized accordingly. The piping should be labeled.

E. Natural Gas System

- *Description* – Natural gas system is comprised of 2" threaded black steel fittings and pipe.
- *Available Data* – No tags were present on the pressure reducing station and there were no complaints from the staff regarding the building being cold during the winter months.
- *Source Age and Capacity* – Based on the lack of complaints, the capacity appears to be ample. The piping on the roofing is 2 inches, but the plans do not indicate what the size of the gas main is from Scituate Avenue
- *Condition* – Natural gas system is in fair condition. The piping on the roof should be painted to avoid rusting.
- *Recommendations* – The piping is well supported but it should be painted and labeled.

2.6.2 Academy Avenue Facility

A. Potable Water Supply from the City

- *Description* – Potable water supply piping enters the building as ductile iron pipe and then transitions to copper piping system for distribution. The backflow preventer has been removed for repairs and there is no bypass installed.
- *Available Data* – Backflow testing does not appear to be up to date evidenced by a lack of up-to-date backflow testing certificates. During the site visit PWSB staff noted that the domestic service backflow preventer was out for repairs. Portions of the piping are copper and some appear to be galvanized piping. Staff also noted that there may be asbestos insulation on the piping. The drawings that we were given by the client indicate that the building was renovated in 1953.

- **Source Age and Capacity** – Potable water supply consists of water service with a backflow preventer. The copper and galvanized piping water distribution system may be 50 years old and feeds the men’s and women’s restroom, a slop sink, electric water cooler and some wall hydrants on the outside of the building and the boiler and heating system components in the Boiler Room.
- **Condition** – The water piping may be more than fifty years old, and should be replaced with new copper piping. All of the piping should be insulated with 1-inch thick fiberglass insulation and properly labeled. Any connections to boiler equipment or hose bibs should be through a separate backflow preventer serving those units.
- **Recommendations** – Reinstall the backflow preventer and conduct required backflow testing and maintain records of when the testing was done. The newly repaired backflow preventer should have a bypass installed around it with another backflow preventer in the event the backflow preventer has to be removed and repaired in the future. Care should be taken to ensure that the unit is not too close to the wall, so that maintenance can be performed on the unit in the future in accordance with the local plumbing code. The water piping serving the handicapped lavatories needs insulation to protect against injury for someone using a wheelchair. All water piping should be insulated and labeled. There are existing cross connections within the facility, and a detailed cross connection survey should be undertaken to correct the piping and eliminate the cross connections.

B. Fire Protection System

- **Description** – Fire protection is of ductile iron pipe at entrance to the hot box and then transitions to black steel for the distribution system in the building.
- **Available Data** – Fire protection inspections are not up to date and lack backflow testing certificates. The fire protection system has been extensively renovated and appears to be in compliance with the code.
- **Source Age and Capacity** – The fire protection system has been recently upgraded. The capacity and source age of the fire protection system are fine. FM-200 is installed in the areas where the servers are installed for the computer systems.
- **Condition** – Fire protection system is in good condition. Sprinkler layouts in the building appear to be adequate and are in conformance with the code.
- **Recommendations** – The fire protection system appears to be well laid out and in conformance with code. Maintain records of when the system is tested annually and make sure that the double check valve is maintained in accordance with local standards. The piping should be labeled. There appears to have been a fire in the hot box from the heating element overheating and burning some of the insulation. This system should be checked and corrected as necessary. If the

heating system in the hot box were to fail, there is a potential for the piping and valves to freeze, resulting in damage to the fire protection system.

C. Sanitary Sewer System

- *Description* – Sanitary sewer system consists of extra heavy cast iron pipe throughout. The cast iron piping is at least fifty years old, and may be significantly older based on conversations with the maintenance staff.
- *Available Data* – The drawings that show some of the cast iron sanitary piping date back to 1953. Some of the maintenance staff indicated to CDM during the walk through of the facility that some of the piping may be original and installed in the late 1800s, which would make it over 100 years old.
- *Source Age and Capacity* – The sanitary piping is old and may have reached its useful life. The drawings show an 8 inch line which appears to be large enough to handle the flow from the sanitary system. The configuration of sewer and storm water piping below grade is unclear.
- *Condition* – The condition of the cast iron piping is questionable. The piping is anywhere from fifty to 100 years old and has most likely met its useful life; replacement should be initiated to avoid leaks in the system.
- *Recommendations* – The cast iron piping system is old and should be replaced. Dye tests should be performed to determine if the systems are combined, and would also help to determine which piping flows to which manholes. Separation of the systems, if required, may be complex and very costly.

D. Storm Water System

- *Description* – Storm water system consists of extra heavy cast iron pipe throughout. The cast iron piping is at least fifty years old and may be significantly older based on conversations with the maintenance staff.
- *Available Data* – The drawings that show some of the cast iron sanitary piping dates back to 1953. Some of the maintenance staff indicated to CDM during the walk through of the facility that some of the piping may be original and installed in the late 1800s, which would make it over 100 years old.
- *Source Age and Capacity* – The sanitary piping is old and may have reached its useful life. The drawings show an 8 inch line which appears to be large enough to handle the flow from the sanitary system. The configuration of sewer and storm water piping below grade is unclear. There are no scuppers or secondary roof drains on the roof and the parapet is 6 feet tall, which could potentially contain a significant amount of water in the event that the roof drainage system becomes plugged. It is highly unlikely that the roof could withstand the additional load of 6 feet of water.

- **Condition** – The condition of the cast iron piping is questionable. The piping is anywhere from fifty to 100 years old and has most likely met its useful life and should start to be replaced to avoid leaks in the system.
- **Recommendations** – The cast iron piping system is old and should be replaced. Dye tests should be performed to determine if the systems are combined, and would also help to determine which piping flows to which manholes. Separation of the systems, if required, may be complex and very costly. A secondary roof drainage system should be installed or scuppers added to meet code.

E. Natural Gas System

- **Description** – Natural gas system is comprised of 2" threaded carbon steel fittings and pipe.
- **Available Data** – No tags were present on the pressure reducing station and there were no complaints from the staff regarding the building being cold during the winter months.
- **Source Age and Capacity** – Based on the lack of complaints, the capacity appears to be ample. The piping enters the building and serves the boiler room from Academy Avenue.
- **Condition** – Natural gas system is in fair condition. The should be painted to avoid rusting.
- **Recommendations** – The piping is well supported but it should be painted and labeled.

2.7 Electrical

2.7.1 Cranston Facility

A. Service Entrance and Distribution System

- **Description** – The utility company serving this facility is Narragansett Electric Company. Electrical service to the building is fed from three pole mounted transformers located on Amy Court on the Northwest side of the building. Power is extended overhead from the utility pole supporting the transformers to a riser pole located on the Cranston property and from the riser pole to a utility metering enclosure located on the South exterior of the building via underground ductbank. The pole mounted transformers and metering are owned and maintained by the utility. The power feed enters the building from the metering enclosure to the main distribution panel (MDP) located in the Maintenance Room, adjacent to the rear building entrance. Power is extended from the MDP to a series of ten load centers located throughout the building via PVC conduit installed in the crawl space below the building. There are no provisions for standby or backup power at this facility.

- **Available Data** – There was no single line diagram available for the system and the descriptions are based on the walk thru and discussions with the operations personnel.
- **Source Age and Capacity** – The MDP is a Siemens Sentron Type S3 panelboard manufactured in 1993 rated 120/208 volts, 400 amperes, three-phase, four-wire. The main and feeder circuit breakers are molded case type circuit breakers. Power consumption and demand information received from the Client indicates a peak demand of 53.90 kW in May 2008, well within the capacity of the existing service. The load centers are Westinghouse Type BR load centers, the manufacturing date is unknown.
- **Condition** – The electrical distribution equipment has been in service for approximately ten years and is in good condition. The Maintenance Room is used as for storage and access to the MDP is restricted by shelving and storage items.
- **Recommendations** – In accordance with the National Electrical Code (NEC), the minimum working clearance in front of electrical distribution equipment in this voltage class is 36-inches. Permanently installed wood shelving restricts the working clearance in front of the MDP to approximately 24-inches. The shelving and containers stored in front of the MDP should be removed to allow free access and working clearance around the panelboard.

B. Building Lighting and Small Power Systems

- **Description** – The building lighting and small power systems were installed new and connected to the various load centers when the building was constructed in 1997. The lighting system consists primarily of recessed fluorescent fixtures providing general lighting throughout the common area. Convenience outlets are located throughout the facility with the exception of the roof.
- **Source Age and Capacity** – The lighting ballast and lamp type are unknown.
- **Condition** – The lighting appears in good shape.
- **Recommendations** – Convenience outlets are required to be installed on rooftops containing HVAC equipment. Receptacle outlets should be installed in accessible locations for use in servicing the rooftop air handling units.

C. Building Fire Alarm System

- **Description** – The fire alarm system was installed in 1997 and appears to be in good working order.
- **Source Age and Capacity** – 1997
- **Condition** – The building fire alarm system is in good condition.

- *Recommendations* – Based on this assessment, there are no apparent needs for immediate repairs or upgrades.

D. Building Telecommunication System

- *Description* – The telecommunication system was installed in 1997 and appears to be in good working order. The PBX system is by Lucent Technologies and is located in a communications room near the Maintenance room. T1 telephone service wiring is routed from the utility riser pole on the Northwest side of the property to the Verizon panel in the communications room. The telecommunications system at this facility is a sub-system connected to the Water Supply Board's main telecommunications system at the Academy Avenue facility.
- *Available Data* – System information was not reviewed during the site visit.
- *Source Age and Capacity* – 1997
- *Condition* – The building telecommunication system is in good condition.
- *Recommendations* – Based on this assessment, there are no apparent needs for immediate repairs or upgrades.

E. Building Security System

- *Description* – The building security system includes fixed cameras monitoring the exterior perimeter of the building and the interior at the front and rear entrance doors. The cameras are monitored from a console in the security room located near the maintenance room. The security cameras are also monitored from the security center in the Academy Avenue facility. The facility has card readers at each building entrance to restrict entry.
- *Available Data* – System information was not reviewed during the site visit.
- *Source Age and Capacity* – 1997
- *Condition* – The building security system is in good condition.
- *Recommendations* – Based on this assessment, there are no apparent needs for immediate repairs or upgrades.

2.7.2 Academy Avenue Facility

A. Service Entrance and Distribution System

- *Description* – The utility company serving this facility is Narragansett Electric Company. Electrical service to the building is fed overhead to a utility riser pole located at the Southwest corner of the building and from the riser pole to a new pad-mounted transformer located on the West side of the building via underground ductbank. The utility revenue meter is located on the side of the

transformer. The pad-mounted transformer and metering are owned and maintained by the utility. The power feed enters the building from the transformer to the main circuit breaker located in a fenced area in the Southwest corner of the maintenance garage via (2) 4" conduits installed overhead through the garage area.

The electrical service and distribution system was upgraded within the past two years, including a new pad-mounted transformer, 800 ampere main circuit breaker, distribution panelboard, lighting panelboards for garage power and lighting and a standby generator with an automatic transfer to provide backup power for security, telephone and miscellaneous systems in the office areas.

Power is extended from the main circuit breaker to panelboard SG-1 and from SG-1 to existing switchboard SG-2 and new lighting panels L-1 and L-2. The majority of the facility is fed from existing switchboard SG-2.

- **Available Data** – There was no single line diagram available for the system and the descriptions are based on the walk thru and discussions with the operations personnel.
- **Source Age and Capacity** – Panelboard SG-1 is a new Square D I-Line panel rated 120/208 volts, 800 amperes, three-phase, four-wire. Switchboard SG-2 was manufactured by Westinghouse and has been in service since the 1950s. The majority of the electrical distribution equipment serving the office and workshop areas, downstream from SG-2, is also old and been in service since the 1950s. The recently installed standby generator is a MagnaPlus generator manufactured by Marathon Electric in 1990 and is standby rated for 55 kW, 69 kVA.
- **Condition** – The front-end electrical distribution equipment is new, has been in service for approximately two years and is in good condition. The majority of the downstream distribution equipment, including switchboard SG-2, was installed in the 1950s with miscellaneous upgrades to support telephone, security and computer systems. It should be noted that the average useful life of the electrical equipment including cables is approximately 25-30 years. Therefore, many of the components (i.e. circuit breakers, contactors, transformers etc.) on this equipment may be worn beyond the manufacturers recommended limits. It is not unreasonable to expect an increase of failures above normal levels of maintenance as this equipment is extended beyond its anticipated life cycle.
- **Recommendations** – Replace the balance of electrical distribution equipment, including panelboards, load centers and associated wiring located throughout the facility.

B. Building Lighting and Small Power Systems

- **Description** – With the exception of the garage area, the building lighting and small power systems were installed when the building addition was constructed in the 1950s. In certain office areas the lighting fixtures were replaced during

various remodeling projects, however none appear to be newer than fifteen years old. The lighting system consists primarily of new low-bay High Intensity Discharge (HID) lighting fixtures in the garage and recessed and surfaced mounted fluorescent lighting fixtures providing general lighting throughout the office and workshop areas. Convenience outlets are located throughout the facility.

- *Source Age and Capacity* - HID lighting in the garage was installed new within the past two years. The fluorescent lighting throughout the office and workshop areas was installed in the 1950s with upgrades in various areas.
- *Condition* - Fluorescent fixture ballast and lamp information was not available during the site visit but all appeared to have been manufactured prior to the use of energy efficient T-8 lamps and electronic ballasts.
- *Recommendations* - Replace all of the older fluorescent lighting fixtures with energy efficient lighting.

C. Building Fire Alarm System

- *Description* - The fire alarm system was upgraded within the past two years and appears to be in good working order.
- *Source Age and Capacity* - 2006
- *Condition* - The building fire alarm system is in good condition.
- *Recommendations* - Based on this assessment, there are no apparent needs for immediate repairs or upgrades.

D. Building Telecommunication System

- *Description* - The telecommunication system was installed in the 1990s and appears to be in good working order. The PBX system is located in a communications room on a mezzanine above the garage with access from the garage. Telephone and communications wiring is routed exposed throughout the garage area, supported from piping systems and routed through holes in brick walls into the office areas.
- *Available Data* - System information was not reviewed during the site visit.
- *Source Age and Capacity* - 1990s
- *Condition* - The building telecommunications system appears to be in good working condition; however, the room above the garage in which the equipment is located is susceptible to dirt, dust, and exhaust fumes. Prolonged exposure in this environment could reduce the reliability and life cycle of the equipment. The exposed telecommunications wiring is also susceptible to damage.

- *Recommendations* - The telecommunications equipment should be relocated to a clean area away from the garage.

E. Building Security System

- *Description* - The building security system includes fixed cameras monitoring the exterior perimeter of the building as well as various locations within the facility. The cameras are monitored from a console in the security center located on the second floor. The facility also has card readers at each building entrance and various office areas to restrict entry.
- *Available Data* - System information was not reviewed during the site visit.
- *Source Age and Capacity* - 1990s
- *Condition* - The building security system is in good condition.
- *Recommendations* - Based on this assessment, there are no apparent needs for immediate repairs or upgrades.

2.8 Costs

2.8.1 O&M Expenses

According to Providence Water records, the following expenses have been incurred for to maintenance, repairs, and improvements at Academy Avenue during the past three years:

- *HVAC* - Repairs and improvements totaling about \$60,000
- *Roof* - Repairs totaling about \$10,000
- *Columns* - Repairs to structural columns totaling about \$15,000
- *Plumbing* - Improvements totaling about \$20,000
- *Carpeting* - Improvements totaling about \$15,000
- *Electrical* - Improvements totaling about \$35,000
- *Windows* - Replacement and/or repairs totaling about \$30,000
- *O&M* - General building maintenance and repairs totaling \$40,000

2.8.2 Repair Costs

In accordance with the assessments detailed in this Section above, following are estimates of present day costs for major repairs and/or improvements expected to be incurred over the next capital planning period of 5-20 years. Total estimated costs include markups of 25% for contractor overhead and profit, plus 25% contingency:

Cranston Facility Improvements:

	Estimated Quantity	Unit	Notes	Estimated Cost
<u>Roof Work</u> Remove & Replace Roof after 10years	12,625	sf		\$300,000
<u>Floor</u> Remove & Replace Carpet Floor in 10 years	450	sy	Assumed 1/3 of 12,625 sf will have carpet	\$27,000
<u>Toilet Partitions</u> Remove & Replace Toilet Partitions	1	ls		\$12,000
<u>Plumbing</u> Insulate the Water Piping/Supports	1	ls		\$1,500
<u>HVAC</u> Retest and Balance all Rooftop Air Conditioning Units	1	ls		\$15,000
Total Estimated Cost:				\$355,500

Providence (Academy Avenue) Facility Improvements:

	Estimated Quantity	Unit	Estimated Cost
<u>Structural</u> Reinforced Wood Columns in Operation Area	1	ls	\$75,000
<u>Roof Work</u> Remove & Replace Roof after 10years	31730	sf	\$725,000
<u>Doors</u> replace doors	1	ls	\$25,000
replace service doors	1	ls	\$55,000
<u>Windows</u> Mindows - Multi-Pane)	1	ls	\$40,000
<u>Finishes</u> Paint/Refinish Floors/New Ceiling Tile/Doors	1	ls	\$400,000
<u>Lockers</u> Remove & Replace Lockers	1	ls	\$40,000
<u>Plumbing</u> Secondary Roof Drainage System/Replace Pipe	1	ls	\$230,000
<u>HVAC</u> Replace Package Rooftop Units & Misc Work	1	ls	\$400,000
<u>Electrical</u> Replace Electrical Distribution Equip & Lighting	1	ls	\$450,000
Total Estimated Cost:			\$2,440,000

As noted, the estimated total cost of repairs and/or improvements is about \$2.8Million. These improvements only address existing equipment and building systems, and do not account for the functional deficiencies in the Academy Avenue site that are discussed further in Sections 3 and 4.

Section 3

Organization and Operations Assessment

3.1 Introduction

Programming consists of evaluating the existing operations and understanding functional relationships, identifying needed improvements and anticipated future growth, and developing the required square footage area of each space. For this project, the process incorporated discussions with PWSB Project Manager Gary Marino, inspection of existing facilities (covered in Section 2), development and analysis of questionnaires to be completed by PWSB staff, interviews with PWSB Directors, and application of experience with public works type facilities in other communities. The questionnaires and interviews are discussed further in this Section.

3.2 Questionnaire Process

A Facilities Programming Questionnaire was prepared which requested information from each Department of the PWSB concerning the following issues:

- Department mission, functional adjacency required to other Divisions, and possible location at a remote site.
- Space, features, location, or adjacency that currently inhibits or could potentially improve efficiency of executing the departmental mission.
- Personnel space requirements for offices, semi enclosed workstations, or open work area.
- Personnel support area requirements for visitor accommodation, conference rooms, eating area, lockers, storage, deliveries and trash disposal.
- Inventory of vehicles and garaging requirements.
- Inventory of mobile equipment and garaging requirements.
- Shop and storage space requirements, including hoists, special mechanical/electrical systems, tools, and building services.
- Outside yard storage area for bulk materials including sand, gravel and yard waste, containers, covered storage, equipment and parking.

A sample questionnaire is included in Appendix C.

3.3 Organizational Chart Review

The latest organization chart for the Providence Water Supply Board was provided by PWSB Project Manager Gary Marino. The chart was reviewed prior to distributing the questionnaire to determine which departments and individuals should participate.

3.4 Participants

Questionnaires were completed by all affected Directors (i.e. does not include treatment plant personnel) and other managers; follow up interviews were then held with the following personnel:

- Administration – Pamela Marchand, Chief Engineer and General Manager; Boyce Spinelli, Deputy General Manager - Administration; Michael Russo, Deputy General Manager - Operations
- Finance – Jeanne Bondarevski, Director
- Engineering – Paul Gadoury, Director
- Commercial Services – Richard Caroulo, Director
- Support Services – Joseph Spremulli, Director
- Facilities and Equipment – Antonio Araujo, Manager
- Transportation and Distribution – Ronald Del Gallo, Acting Director
- Information Systems – David DelSesto, Senior Manager

3.5 Questionnaire and Interview Response

The purpose of the questionnaires and interviews was to determine needs and functional issues of the departments. Generally, employees are able to complete their work given the current accommodations. Some concerns and deficiencies were noted throughout this process, and suggestions for improvements were made as well. In conjunction with the site inspections and interview process, CDM has observed and compiled the following site specific issues:

3.5.1 Cranston Facility Comments

- Off-site location of Administration and Support Services hinders communications and causes delays.
- Work stations for visiting auditors and consultants are needed.

- File storage space is needed for documents and records, and to improve security and safety (records are currently stored in existing pumping station on site).
- Conference room availability and scheduling are a problem.
- A large multi-purpose room is needed for conferences, presentations, training, and to facilitate an emergency command center when needed.
- Lockers, changing, and shower facilities needed for employees engaged in field work and related activity.
- A receiving area and loading dock for deliveries is needed.
- Storage for equipment and supplies is limited.
- Although a small office is currently utilized for the purpose, there is no separate dedicated computer server room; Limited backup power is provided for existing equipment.
- Work surfaces in cubicles are too narrow for drawings.
- Efforts to accommodate growth and the need for storage have evolved into a less optimum use of floor space.

3.5.2 Academy Avenue Facility Comments

- Truck traffic on neighboring streets is not allowed, hampering system maintenance operations.
- The single site entrance and access road is a safety hazard for visitors and employees, with PWSB vehicles and deliveries entering and leaving the site.
- Conflicting/common use of the access road creates delays and a bottleneck that sometimes extends into Academy Avenue.
- Large trucks making deliveries to the central stock room or yard storage areas are not able to maneuver safely into the yard due to restricted aisles and turning space, and frequently must be unloaded by forklifts while parked on Academy Ave, resulting in a serious hazard to traffic and pedestrians.
- Parking for employees and PWSB vehicles in the yard is inadequate, and restricted aisle space has caused accidents and damage to vehicles.

- Storage and handling of bulk materials (i.e., stone, fill, waste) is limited, and maneuvering space for trucks and loaders is severely restricted.
- Vehicle fueling adds to the yard congestion and risk of damage.
- Snow removal is a problem due to the lack of yard space to move and store it.
- There is no visual or sound buffer/barrier between the yard and adjoining properties, and the building is built to the property line on the north and east.
- The building is too small and too restricted by structural columns to accommodate the recommended vehicle garaging (see Section 4).
- The building is too small to accommodate programmed needs for maintenance bays, workshops, and storage (see Section 4).
- The building is too small to accommodate department offices and spaces serving field staff.
- If department offices were relocated, the building space is not adaptable for vehicle garaging, maintenance bays, and workshops.
- If vehicles, maintenance bays, and storage were relocated, the vacated building space is poorly suited for offices and personnel spaces.
- The building envelop is energy inefficient due to lack of insulation, and concern over weathertightness of windows and doors.
- The building heating and ventilation systems are somewhat antiquated. Air quality of employee areas is impacted by poor isolation and ventilation of office and vehicle spaces, especially where they abut each other.
- The building structure has been damaged in several locations by impact (i.e., vehicles) and roof leaks.
- A major capital investment for physical improvements to the building would not solve space congestion and functional deficiencies due to size and layout.
- The site is too small to accommodate programmed needs for parking employee, visitor, and PWSB vehicles and materials storage (see Section 4).
- The site has one entrance, causing frequent conflicts between vehicle access, materials loading, and pedestrians.
- Site abutters include a private school and small residential lots, making the purchase of additional land for expansion highly unlikely.

Section 4

Needs Assessment

4.1 Program Data

Raw data from work performed under Section 3 was compiled and reviewed by PWSB Project Manager Gary Marino. Adjustments to projections for anticipated future Departmental structure and equipment needs were also considered. In addition, vehicle and equipment sizes were verified and tabulations updated.

The following Tables reflect the anticipated Departmental needs for building space and yard storage:

- **Table 4.1 - Departmental Space Requirements:** Lists rooms and required area for Division offices, meeting rooms and personnel areas and related storage, areas for vehicle/equipment maintenance and parts storage, and specialty workshops. Schematic room plans are appended to describe the basis for many tabulated room areas.
- **Table 4.2 - Shared Department Facilities:** Lists information collected about conference room usage and allocation, office and field staff locker needs, and common rooms shared by departments.
- **Table 4.3 - Vehicle, Equipment and Employee Parking:** Lists vehicles and equipment of each Department that are currently garaged and recommended to be garaged in a heated building to assure rapid mobilization during the winter season, and to prevent freezing, extend useful life, and ensure security. It describes space required for two garaging options, one with drive parking bays, and a second with internal drive aisles for access to parking spaces. Outside parking space required for Department and employee vehicles is also tabulated.
- **Table 4.4 - Site Size:** Includes the two options for PWSB vehicle garage configuration, and considers the building and site area required for current and recommended numbers of vehicles for garaging. Lists outdoor areas for bulk materials storage and waste handling, employee and visitor parking. A modest open space allowance is included to account for site shape, topography, access, screening and buffer area from adjoining properties and zoning setbacks. Together these total in excess of 5 acres, suggesting a 6 acre site should be targeted to accommodate all current operations.

4.2 Facilities Sketches

In conjunction with the programming tables discussed in Section 4.1, sketches of the individual spaces described above were developed, and are attached following Tables 4.1 through 4.4.

Program Data Sheet

ID	Department	Director	No Employees		Position	Office Number	Size (nsf)	Total (nsf)	Cubicle Number	Size (nsf)	Total (nsf)	Open Area Number	Size (nsf)	Total (nsf)	Storage Room Use	Large (nsf)	Med (nsf)	Small (nsf)	Total (nsf)	Other Room Purpose	Area (nsf)
			Men	Women																	
A6.0	Support Services	Joe Sprenull		21	g																
A6.1					Director	1	200	200													
A6.2					Mgr Int Govt Rel	1	168	168													
A6.3					Mgr Facil & Equip	1	168	168													
A6.4					Mgr Safety & Risk	1	168	168													
A6.5					Mgr Security	1	300	300													
A6.6					Mgr Personnel	1	168	168													
A6.7					Aide to Chief				2	72	144										
A6.8					Claims Administrator				1	72	72										
A6.9					Supv Personnel				1	72	72										
A6.10					Supv Purchasing				2	72	144										
A6.11					Automotive Clerk							1	45	45							
A6.12					Stockroom Clerk							1	45	45							
A6.13					Purchasing Agent							1	45	45							
A6.14					Purchasing Clerk							1	45	45							
A6.15					Switchboard Clerk							1	45	45							
A6.16					Personnel Clerk							2	45	90							
A6.17															Records	1000					
A6.18															Personnel Files			100			
A6.19															Copy paper			100			
A6.20															Janitor			100			
A6.21															Yard Maint Eq			400			
A6.22															Furniture/Off Equip	600					
A6.23															Stock Room	6000					
A6.24															FlammaComb Mat			120			
A6.25															Tools, Parts, Equip			600			
A6.26																					
A6.27																					
A6.28																					
A6.29																					
A6.30																					
A6.31																					
A6.32																					
A6.33																					
A6.34																					
A6.35																					
A6.36																					
							subtotal (nsf)	1,172	subtotal (nsf)		432	subtotal (nsf)		315			subtotal (nsf)	6,020			18,800

Program Data Sheet

Part B SHARED FACILITIES

Conference Room Programmed Use

Dept User	Frequency	Mtg Length	Ave hr/wk	Seating	Comment
Finance	2 per mo.	1-2 hrs	1	12	See Common Rooms
Comm Svcs	1 per week	1 hour	1	12	See Common Rooms
Engineering					See Common Rooms
MIS				10	See Common Rooms
T&D				8	See Common Rooms
Personnel				6	See Common Rooms
Support Services					See Common Rooms

Office Staff Locker Room Programmed Need

Department	User	Locker		Dirty Lkrs		Comment:
		Men	Women	Men	Women	
All	Office Staff	6	6			Lockers Size: 12" x12" x 72"
	total	6	6	0	0	Unassigned for general use

Road Staff Locker Room Programmed Need

Department	User	Locker		Dirty Lkrs		Comment:
		Men	Women	Men	Women	
Commercial Services Support Services	Meter Techs	21	5			Lockers Size: 12" x12" x 72"
	Fac Maint & Auto Rep Techs	12	3	Dirty uniform hamper	Dirty uniform hamper	Allowance of 25% for women
	Road Staff	45	11	Dirty uniform hamper		Allowance of 25% for women
	total	78	20	0	0	98

Program Data Sheet

Office Staff Other Common Rooms

ID	Space	No Rooms	Size (nsf)	Area (nsf)	Comment:
B.01	Reception/Lobby	1	400	400	Building, with receptionist/switchboard
B.02	Copy Room	1	144	144	
B.03	Lunch Room	1	1,280	1,280	Seating 50 people, kitchenette, vending
B.04	Men's Restroom	1	290	290	
B.05	Men's Locker Room	1	220	220	22 lockers
B.06	Women's Restroom	1	290	290	
B.07	Women's Locker Room	1	220	220	22 lockers
B.08	Deliveries/Recycle	1	168	168	
B.09	Training Room	1	800	800	Seating 50 at chairs, divisible in half
B.10	Conference Rooms	7	240	1,680	Seating 12 at table
			subtotal (nsf)	5,492	
			Net to Gross Factor	0.70	
			Program Gross Area (gsf)	7,846	

Road Staff Other Common Rooms

ID	Space	No Rooms	Size (nsf)	Area (nsf)	Comment:
B.11	Lunch Room			0	Combined with Ready Room
B.12	Men's Restroom	1	290	290	
B.13	Men's Locker Room	1	640	720	100 lockers, 2 showers
B.14	Women's Restroom	1	208	208	
B.15	Women's Locker Room	1	220	220	22 lockers, 2 showers
B.16	Uniform Locker Room	1	105	105	100 - 6x12x36 lockers, and dirty uniform hamper provided by laundry vendor
B.17	Ready Room	1	700	700	Seating 24 people, kitchenette, vending
			subtotal (nsf)	2,243	
			Net to Gross Factor	0.70	
			Program Gross Area (gsf)	3,204	

Program Data Sheet

Part C VEHICLE PARKING

Department	Vehicle No.	Description	Parking Space Size (nsf)			Total Drive Thru	Drive Aisle (nsf)	Total w/ Aisles	
			9 x 20	12 x 20	12 x 24				12 X 30
Supp Services	427	International Dump		240		240	150	390	
Supp Services	214	Chev Utility		240		240	150	390	
Comm Services	229	Ford 450 (Emerg)			288	288	150	438	
T & D	48	John Deere Backhoe*				360	150	510	
T & D	83	Chev Van (Crew)		240		240	150	390	
T & D	121	Chev Kodiak			288	288	150	438	
T & D	150	Chev Stakebody			288	288	150	438	
T & D	160	Chev Dump		240		240	150	390	
T & D	197	Ford Dump		240		240	150	390	
T & D	499	GMC-350				0		0	
T & D	252	GMC Lt Utility		240		240	150	390	
T & D	278	Ford Backhoe*				360	150	510	
T & D	541	Chev Stakebody			288	288	150	438	
T & D	626	Intl Vac Excavator*				360	150	510	
T & D	868	Chev Van (Crew)		240		240	150	390	
T & D	895	NEWH Backhoe*				360	150	510	
T & D	935	Chev Van (Crew)		240		240	150	390	
T & D	954	Sterling Dump Patch Truck*				360	150	510	
T & D	986	Ford F-800			288	288	150	438	
T & D	1001	Chev W4S Valve Tru		240		240	150	390	
T & D	1554	Ford F-800			288	288	150	438	
T & D	2444	Ford Backhoe*				360	150	510	
T & D	2533	Ford Sterling Hoist*				360	150	510	
T & D	3441	Ford Backhoe*				360	150	510	
T & D	1348	John Deere 410G Backhoe*			288	288	150	438	
Spare Spaces	6	2 each size		480	576	720	450	2,226	
Total Vehicles		30	Proposed Program Net Area (nsf)			8,832			12,882
			Net to Gross Factor			0.90			0.90
			Proposed Program Gross Area (gsf)			9,813			14,313
			*Total Currently Garaged Only (nsf)			4,944			6,744
			Net to Gross Factor			0.90			0.90
			*Total Currently Garaged Only (gsf)			5,493			7,493

Program Data Sheet

PWSB Vehicles Proposed for Outdoor Parking				Parking Space Size (nsf) 9 x 20	Drive Aisle (nsf)	Total w/ Aisles (nsf)
Department	No. Vehicles	Description				
Support Services	9	Cars & Pickups		1,620	1,800	3,420
Commercial Svcs	16	Lt Util, Vans, Cars		2,880	3,200	6,080
Engineering	13	SUV, Pickups, Cars		2,340	2,600	4,940
Finance	2	Cars & Pickups		360	400	760
T&D	21	SUV, Pickups, Cars		3,780	4,200	7,980
Administration	1	Car		180	200	380
Spare Spaces	6	Passenger Vehicles		1,080	1,200	2,280
Total Vehicles	68		Proposed Program Net Area (nsf)			25,840

Add heavy vehicles not currently garaged	427, 214, 229, 83, 121, 150, 160, 197, 252, 541, 868, 935, 986, 1001, 1554.	2,160	1,728	2,250	6,138
--	---	-------	-------	-------	-------

Required for Current Vehicles Parked Outdoors (nsf) 31,978

Other Proposed Outdoor Parking				Parking Space Size (nsf) 9 x 20	Drive Aisle (nsf)	Total w/ Aisles (nsf)
	No. Vehicles	Description				
Road Employee Parking	81	Passenger Vehicles		14,580	16,200	30,780
Spare Spaces	8	Passenger Vehicles		1,440	1,600	3,040
Office Employee Parking	104	Passenger Vehicles		18,720	20,800	39,520
Spare Spaces	10	Passenger Vehicles		1,800	2,000	3,800
Visitor Parking	15	Passenger Vehicles		2,700	3,240	5,940
Total Vehicles	218		Program Net Area (nsf)			83,080

Yard Storage

Program Data Sheet

SITE SIZE

Vehicle Garaging Option	One Story Building Area (gsf)			Outdoor Area (sq. ft.)			Total Building (gross sq. ft.)	Total Useable Outdoor Space (sq. ft.)	Total Site Occupied (sq. ft.)	Open Space Allowance add 20% (sq. ft.)	Minimum Site Area		
	Dept Personnel	Vehicle Drive-thru	Access Aisles	PWSB Vehicle Parking	Yard Storage Allowance	Employee Parking					Visitor Parking	Square Feet	Acres
A1 - All Heavy Vehicles Garaged	60,457	9,813		25,840	15,000	77,140	5,940	123,920	194,190	38,838	233,029	5.35	
A2 - All Heavy Vehicles Garaged	60,457		14,313	25,840	15,000	77,140	5,940	123,920	198,690	39,738	238,429	5.47	
B1 - Only Existing Heavy Vehicles Garaged	60,457	5,493		31,978	15,000	77,140	5,940	130,058	196,008	39,202	235,210	5.40	
B2 - Only Existing Heavy Vehicles Garaged	60,457		7,493	31,978	15,000	77,140	5,940	130,058	198,008	39,602	237,610	5.45	

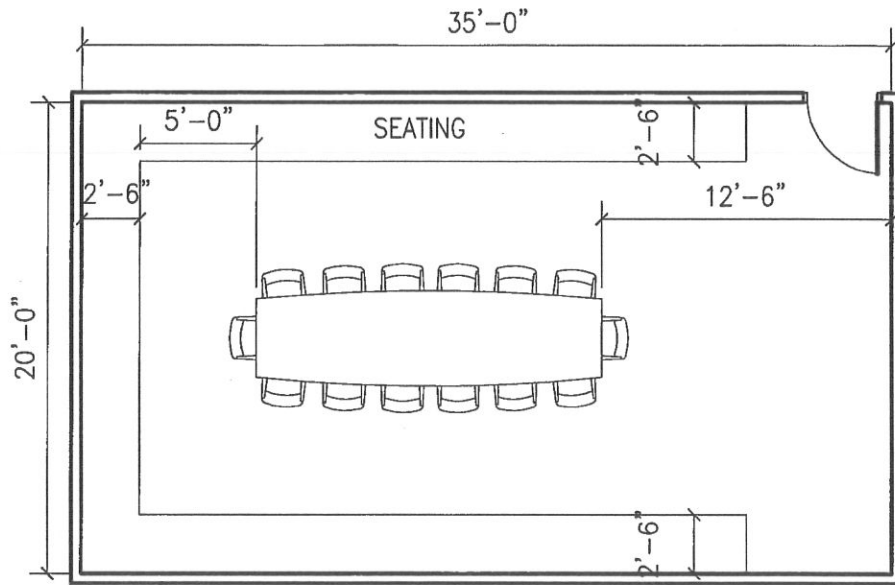

A1.9 BOARD ROOM 700sf

PLAN

1/8" = 1'-0"

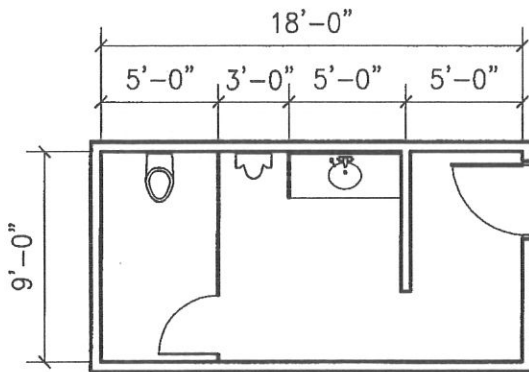

A1.10 BOARD ROOM TOILET 160sf

PLAN

1/8" = 1'-0"

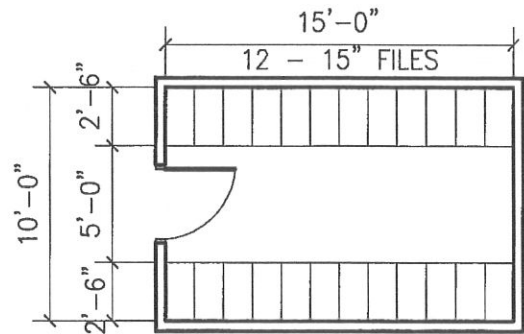

A2.7 FILE ROOM 150sf

PLAN

1/8" = 1'-0"

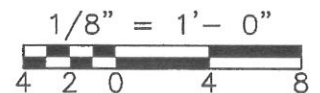

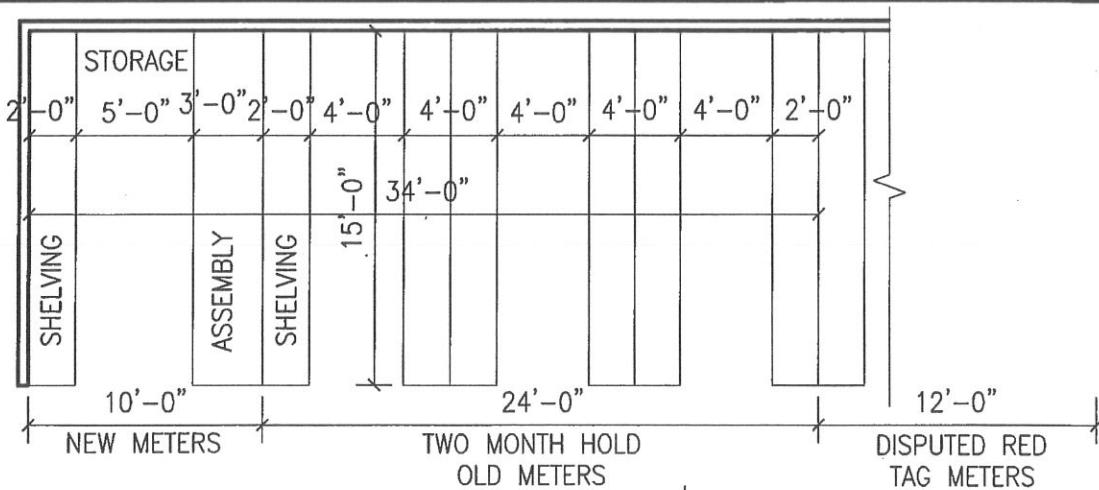

A3.9, A3.10, A3.11, A3.12
METER STORAGE 870sf
PLAN

$1/8" = 1'-0"$

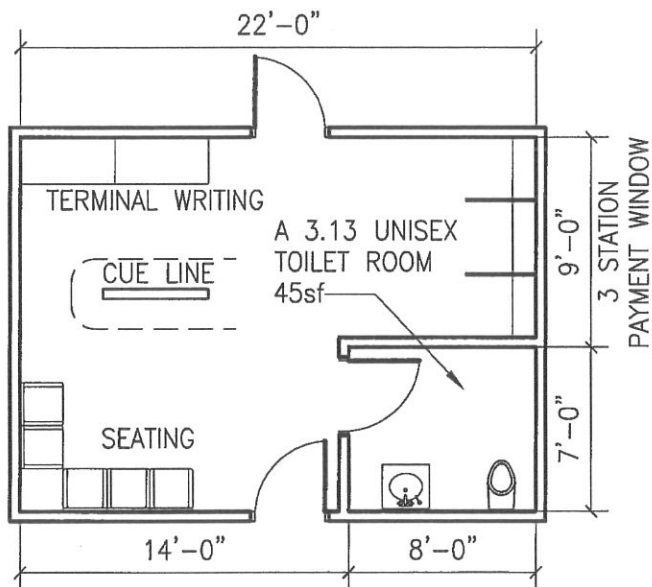
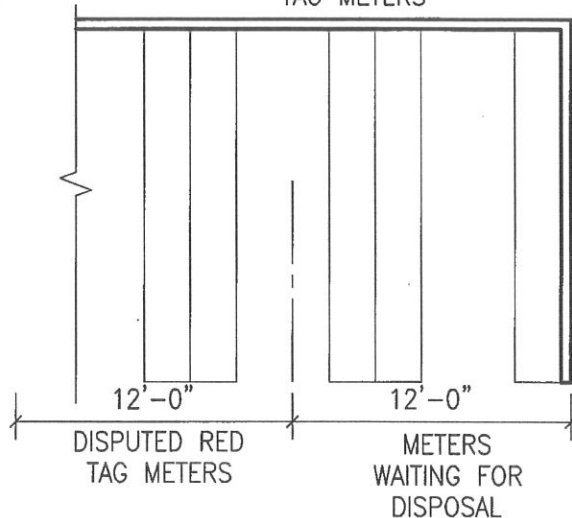

A3.13 BILL PAYING LOBBY 375sf
PLAN

$1/8" = 1'-0"$

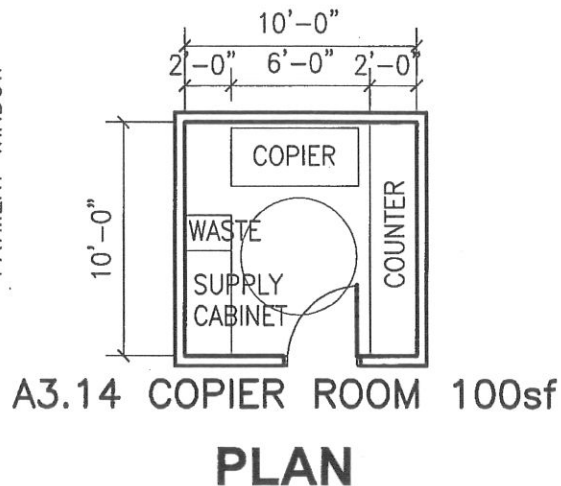

A3.14 COPIER ROOM 100sf
PLAN

$1/8" = 1'-0"$

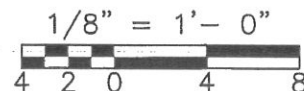

A 3.16 METER
SHOP 400sf
PLAN

1/8" = 1'-0"

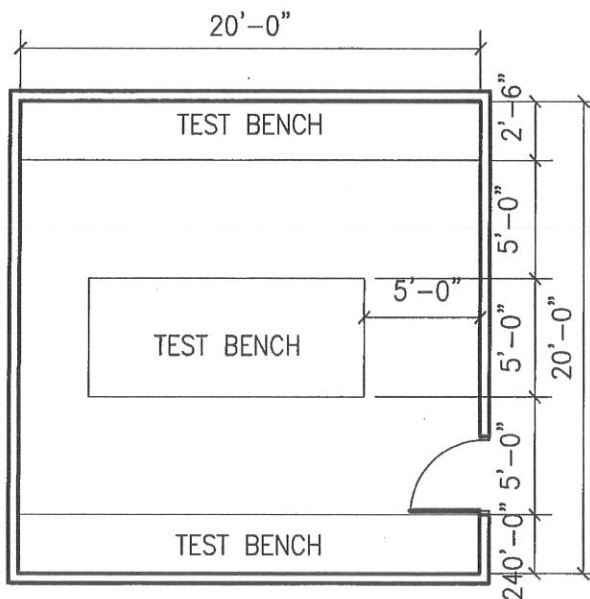

A 5.18 ENGINEER FIELD
EQUIPMENT STORAGE 210sf
PLAN

1/8" = 1'-0"

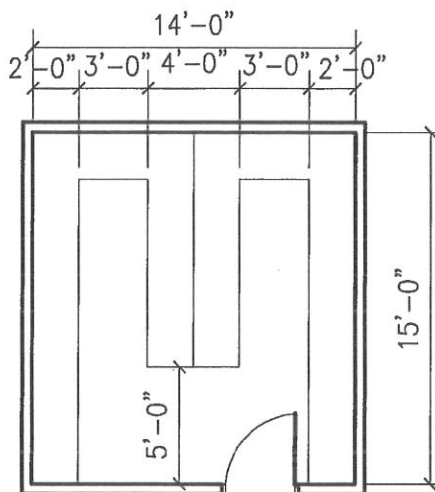

A 6.28 TELEPHONE
ROOM 200sf
PLAN

1/8" = 1'-0"

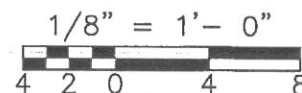
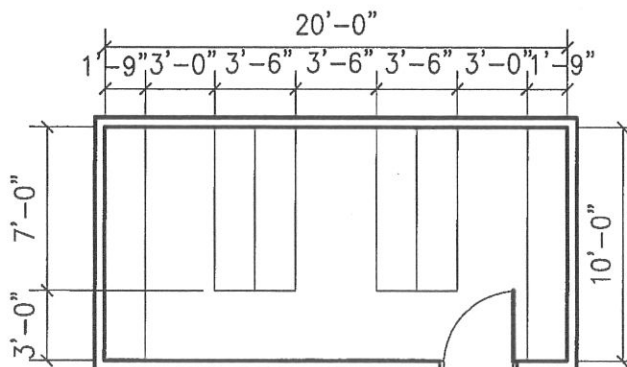

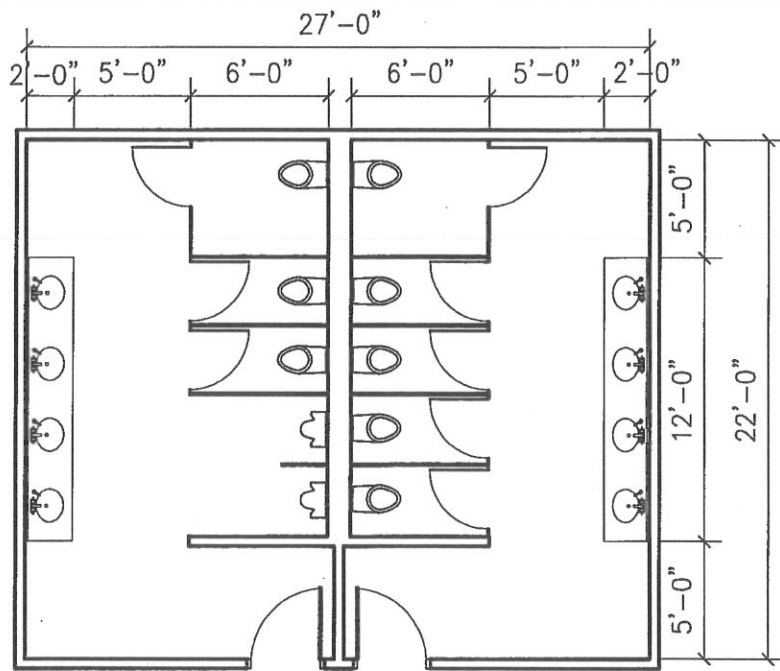

B.04,B.12 MEN AND B.06 WOMEN TOILET ROOMS 290sf EA.

PLAN

1/8" = 1'-0"

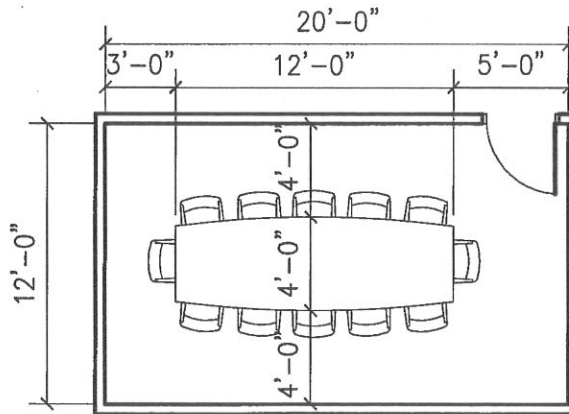

B.10 CONFERENCE ROOM 240sf

PLAN

1/8" = 1'-0"

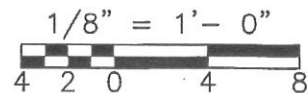

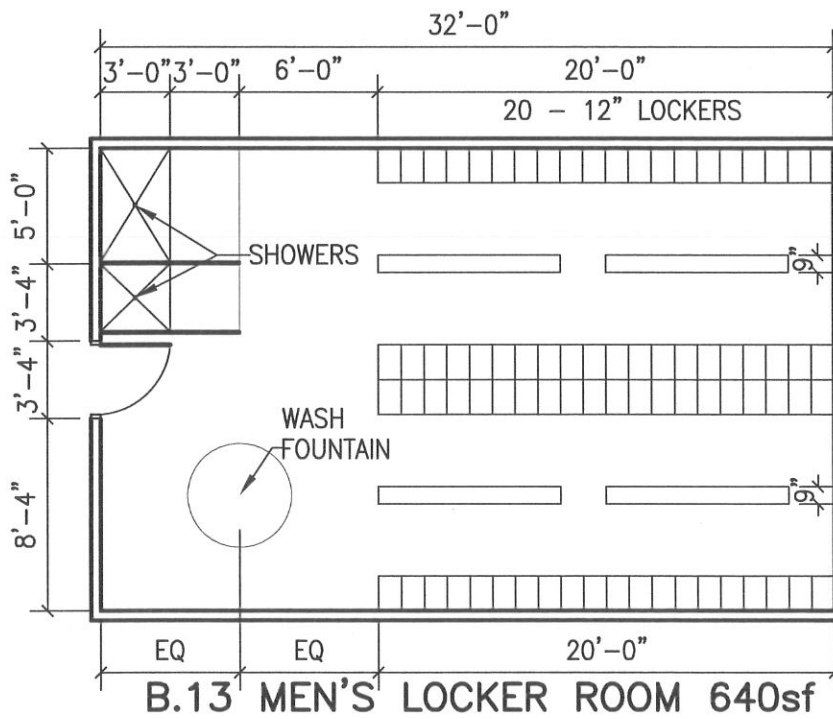

PLAN

1/8" = 1'-0"

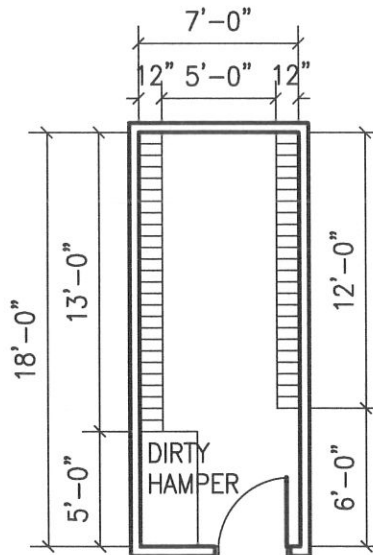

PLAN

1/8" = 1'-0"

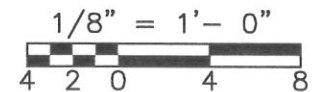

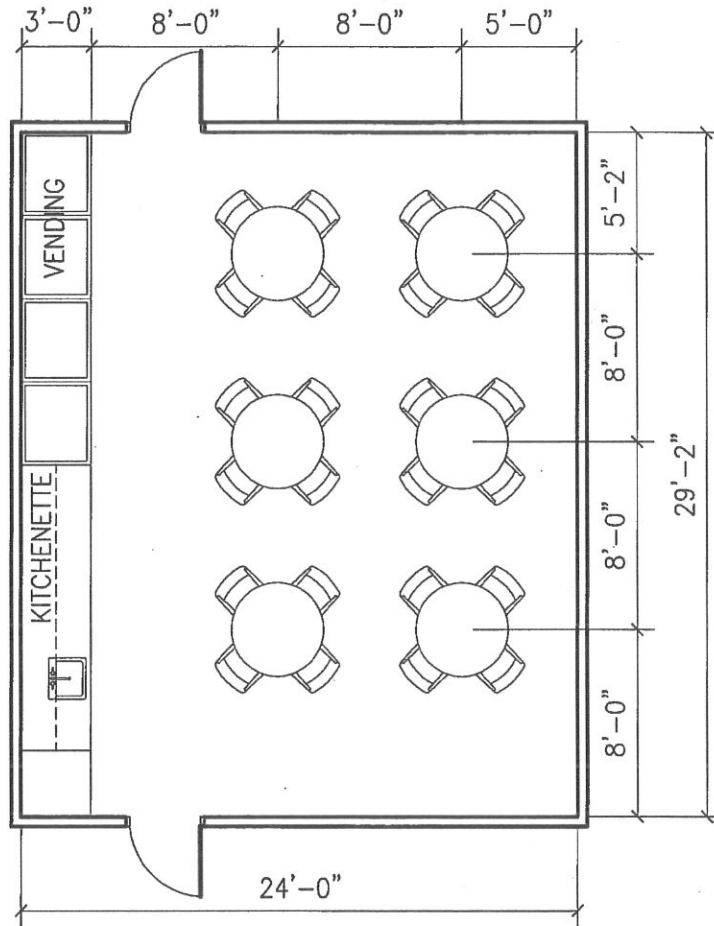

B.17 READY ROOM 700sf

PLAN

$1/8" = 1'-0"$

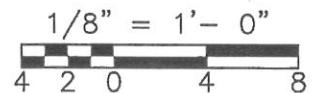

Section 5

Summary

5.1 Summary

Work performed under Phase I of the project included data collection, facilities assessments, questionnaires and staff interviews, and the development of a program identifying optimum space for all personnel currently working at the Cranston and Academy Avenue facilities.

Although the use of space has become a challenge given the responsibilities of the different departments located at the Cranston site, the building is generally in good condition.

Many of the Academy Avenue building facilities components are approaching or well beyond their useful service life, and the upgrades required to bring all components into compliance with current codes, plus periodic repair or replacement over the next capital planning period, represents a substantial investment and rehabilitation program. Many of these upgrades would entail substantial disruptions to current operations, which are currently stressed by the conditions of the building and the constraints of the site. Further, logistical and safety concerns indicate that the facility is not meeting the needs of PWSB staff or its customers, and these concerns would not be addressed by equipment and code updates. Given these considerations, the long term efficient operations of the PWSB would appear to be best served by relocating the Academy Avenue facility.

This report summarizes work and results from Phase I; additional analysis and recommendations are to be developed in Phase II, including the following:

- Evaluation of various site configurations, including maintaining current separate facilities.
- Consideration of different combinations of departments at existing or new sites.
- Market data evaluation to identify potential properties meeting the program needs identified herein.
- Final reporting with implementation suggestions to help meet the needs of the Providence Water Supply Board.

Appendix A - List of Collected Data

Providence Water Supply Board
Facilities Study
Appendix A - List of Collected Data

Item:

PWSB Vehicle List
Service Area Map
CIP Misc. Info
Breakdown of Personnel
PWSB Building List
Service Area Map (2)
PW Personnel and Titles
Aqueduct and Academy Utility Bills
Aqueduct Filing Cabinet List

Drawings:

Aqueduct Office Floor Plan
Academy Ave Second Floor Plan, 1953
Academy Ave First Floor Heating Plan H-1, 1953
Academy Ave First Floor Plumbing Plan P-1, 1953
Academy Ave Plat Plan 1, 1953
Aqueduct Site Plan C-1, 1997
Aqueduct Building Plan & Section S-1, 5/20/97
Aqueduct Building HVAC Plan h-1, 5/20/97
Aqueduct Building Foundation Plan S-1, 7/2/97
Aqueduct Building Sprinkler Plan 21497-1, 7/11/97
Aqueduct Building Structural Details & Notes S-2, 7/2/97
PW Organizational Chart

Received:

Gary Marino email 4/8/08
Gary Marino email 4/8/08
Mead email 4/10/08
Gary Marino email 4/10/08
Gary Marino email 4/10/08
Gary Marino email 4/10/08
Gary Marino email 4/10/08
Gary Marino email 4/12/08
Gary Marino email 5/23/08
Gary Marino email 7/3/08

Received:

Gary Marino email 3/5/08
Gary Marino email 4/2/08
Gary Marino email 4/2/08
Gary Marino email 4/2/08
Gary Marino email 4/2/08
Gary Marino email 4/2/08
Gary Marino email 4/2/08
Gary Marino email 5/23/08
Gary Marino email 5/23/08
Gary Marino email 5/23/08
Gary Marino email 5/23/08
Gary Marino email 5/23/08
Gary Marino email 5/23/08
Received from Gary Marino

Appendix B – Inspection Photos

CRANSTON SITE INSPECTION PHOTOGRAPHS



Cranston Facility



Cranston Roof

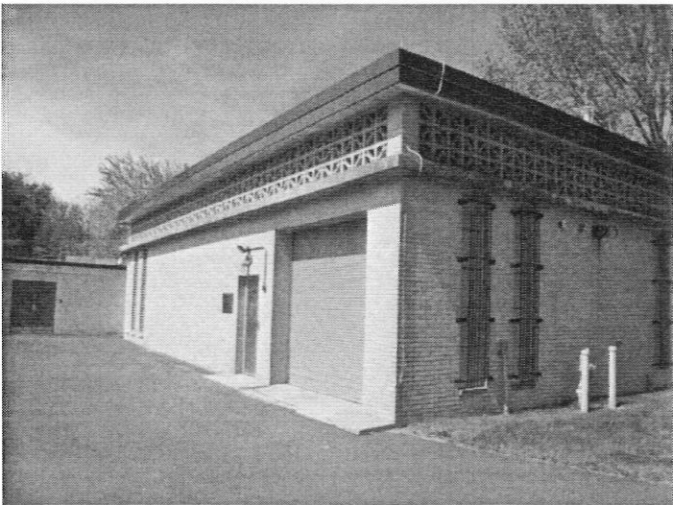

Cranston Pump Station/Records Storage

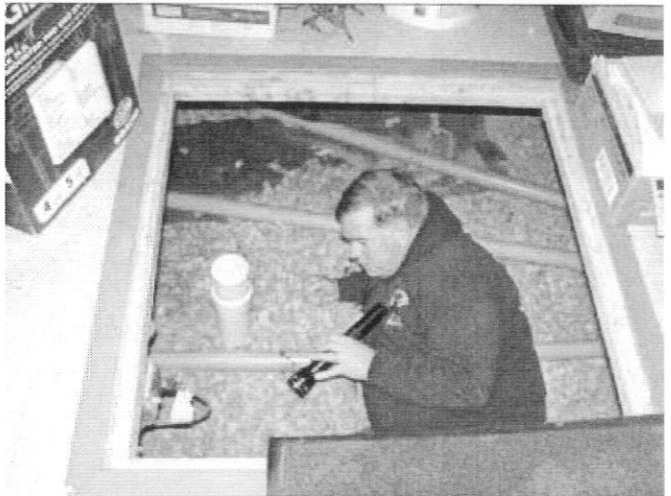

Cranston Crawl Space Access

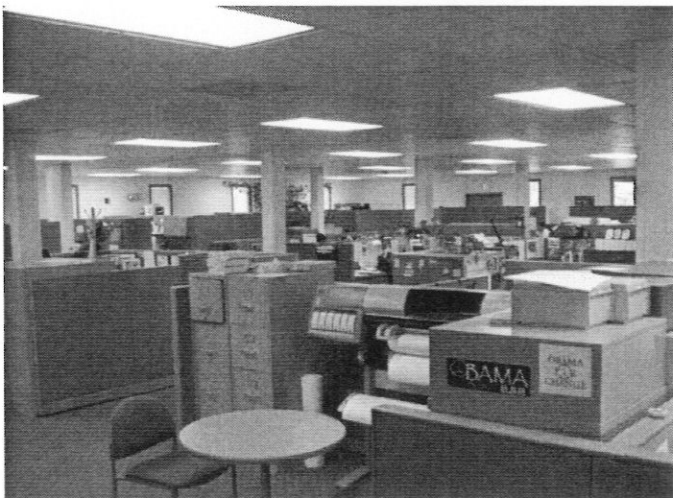

Cranston Interior – Plotter Location



Cranston Interior – Cubicles and Storage

CRANSTON SITE INSPECTION PHOTOGRAPHS

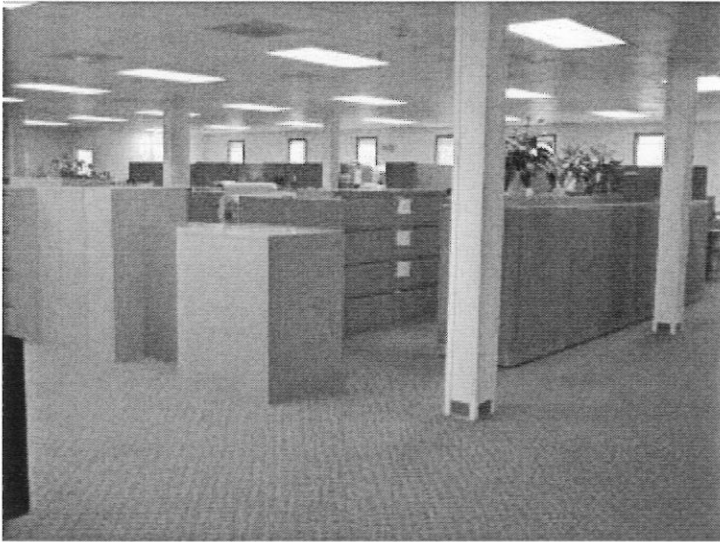

Cranston Interior – File Storage

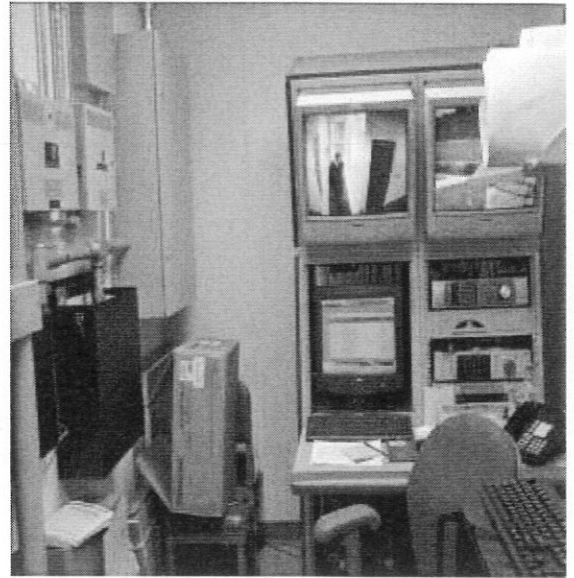

Cranston Interior – Security



Cranston Electrical Panels

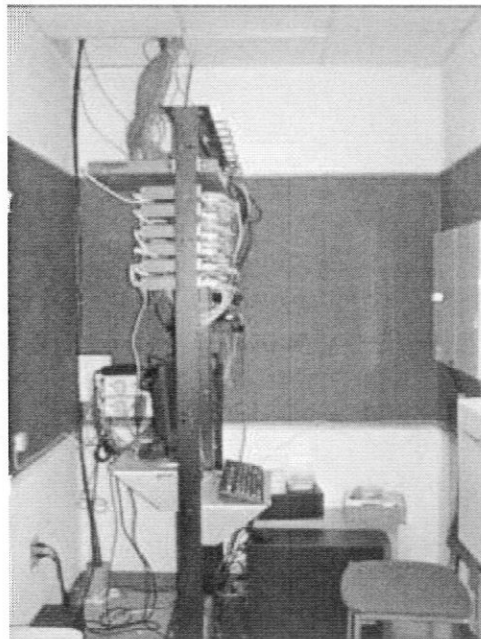

Cranston Server Equipment

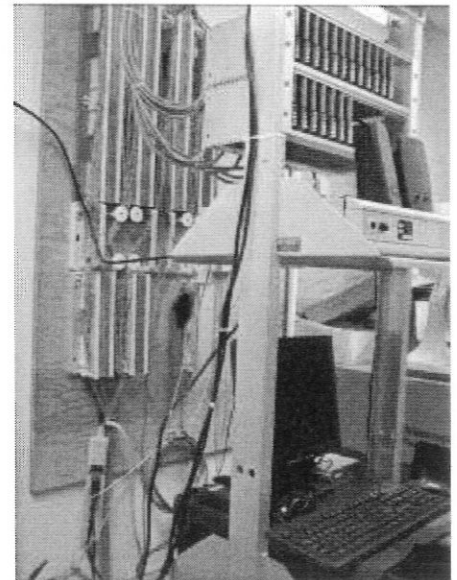

Cranston Telephone Equipment

PROVIDENCE (ACADEMY AVENUE) SITE INSPECTION PHOTOGRAPHS



Providence Building Facade



Providence Visitor Entrance



Providence Building Rear

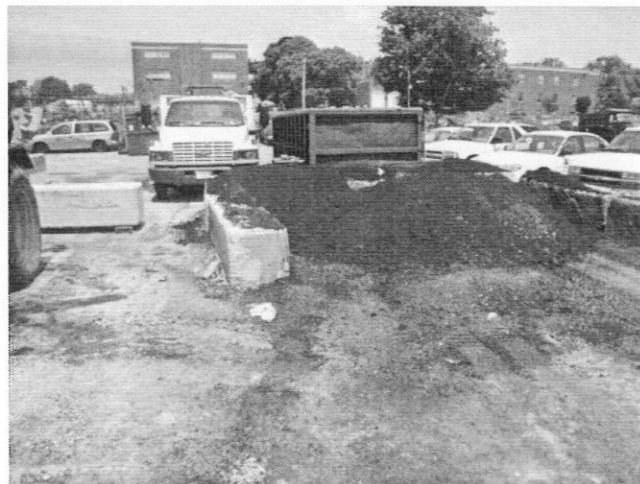

Providence Materials Storage



Providence Materials Storage



Providence Parking

PROVIDENCE (ACADEMY AVENUE) SITE INSPECTION PHOTOGRAPHS

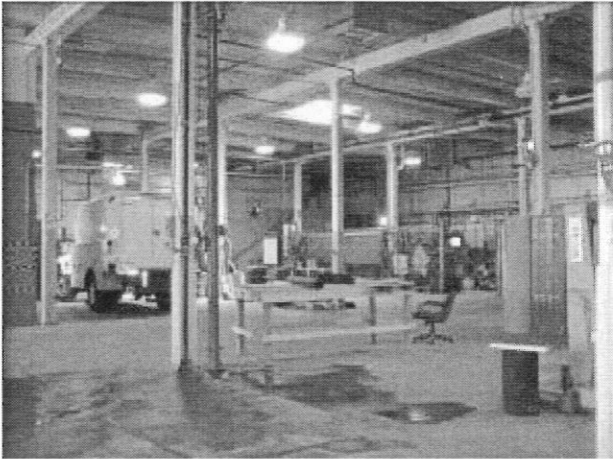

Providence Garage Interior



Providence T&D Stock Room

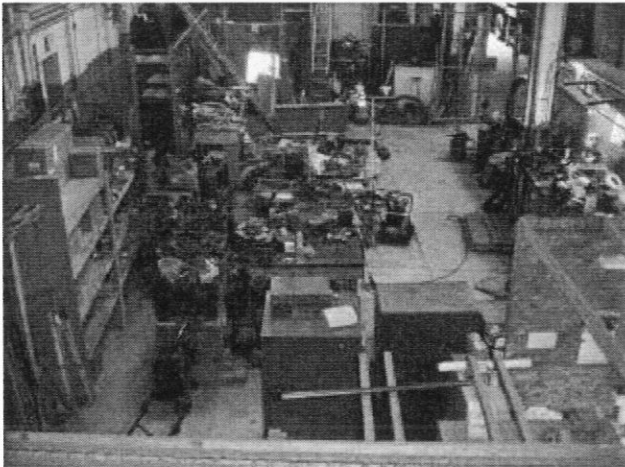

Providence Garage Storage

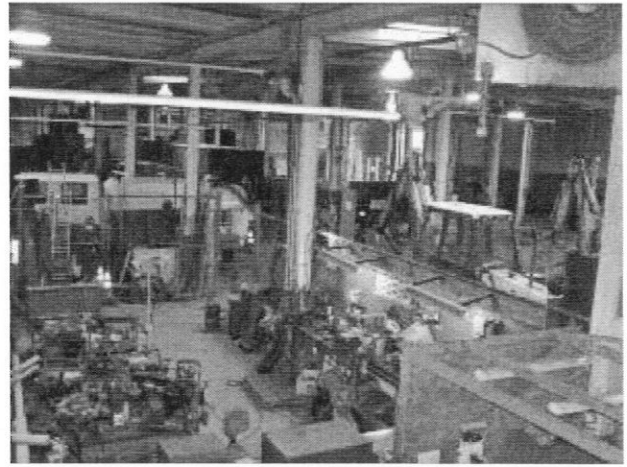

Providence Garage Storage

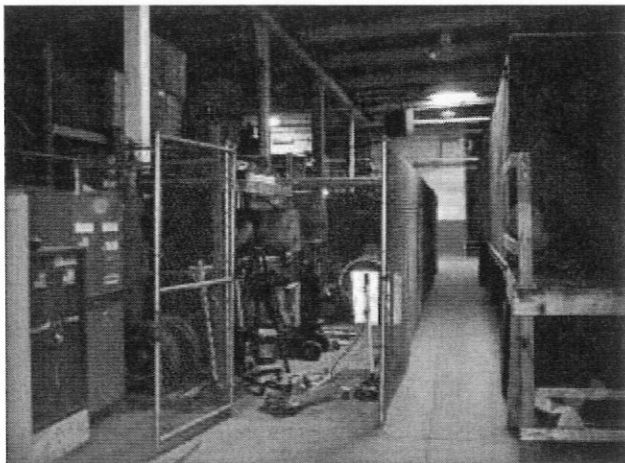

Providence Garage Storage Trailer



Providence Vehicle Maintenance

PROVIDENCE (ACADEMY AVENUE) SITE INSPECTION PHOTOGRAPHS



Providence Electrical Gear

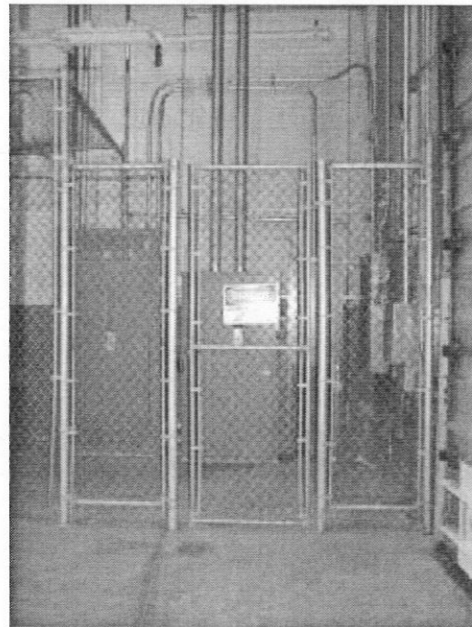

Providence Electrical Service

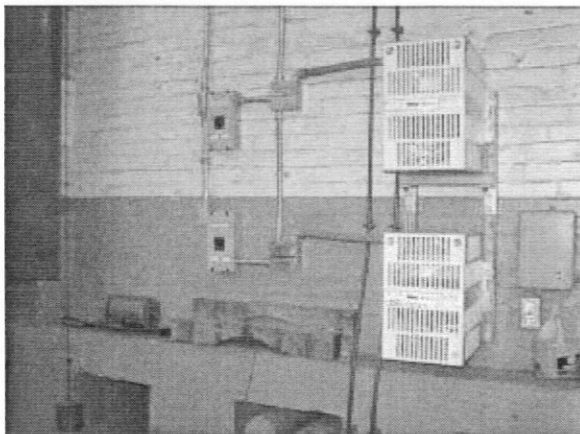

Providence Electrical Equipment



Providence Phone Equipment



Providence Garage Rest Room



Providence Security Room

PROVIDENCE (ACADEMY AVENUE) SITE INSPECTION PHOTOGRAPHS



Providence Roof

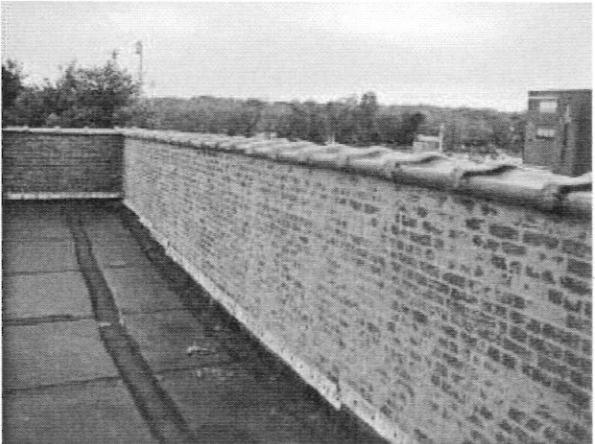

Providence Roof Wall



Providence Meter Room

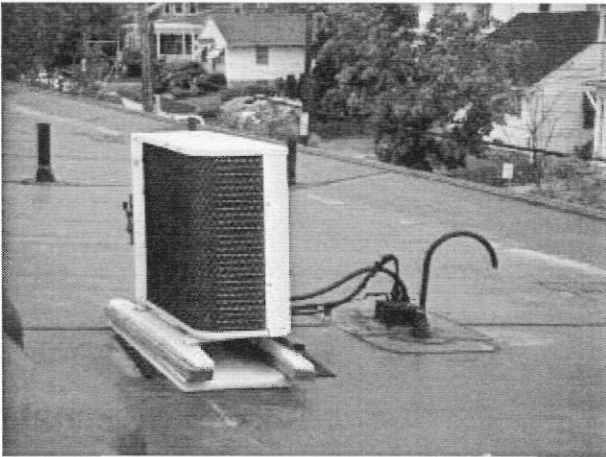

Providence Roof Equipment

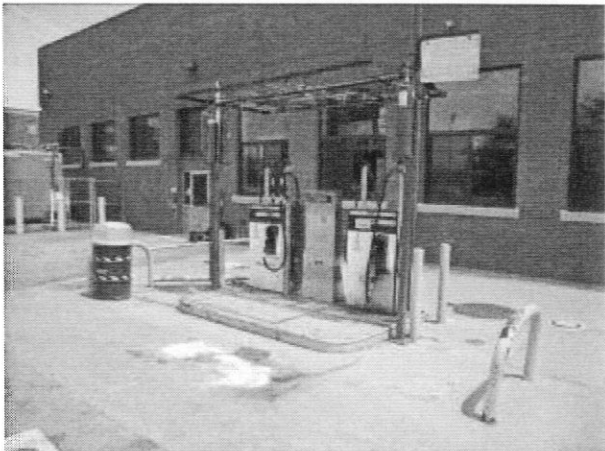

Providence Gas Pumps

PROVIDENCE (ACADEMY AVENUE) SITE INSPECTION PHOTOGRAPHS

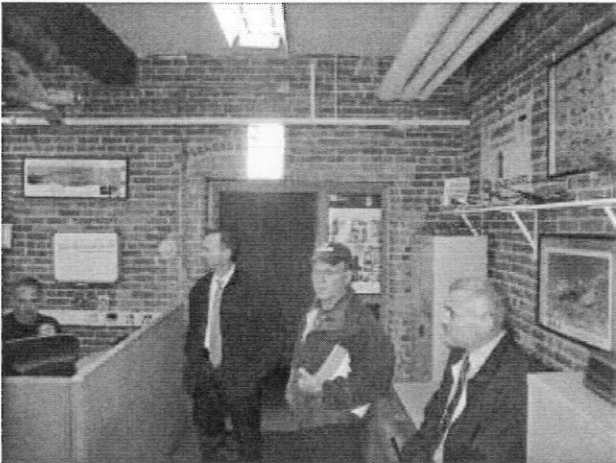

Providence Garage Offices



Providence Board Room

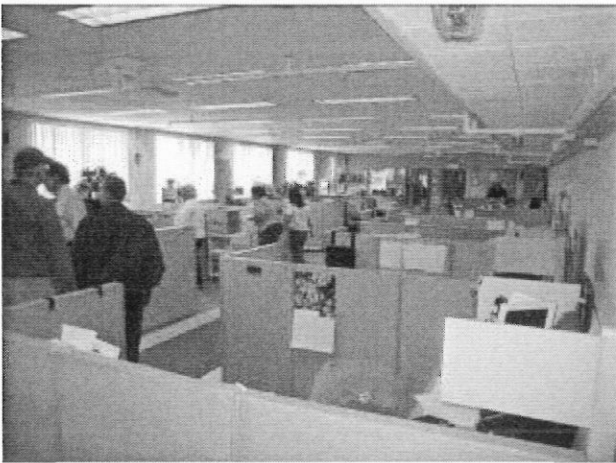

Providence Customer Service Area



Providence Customer Service Area

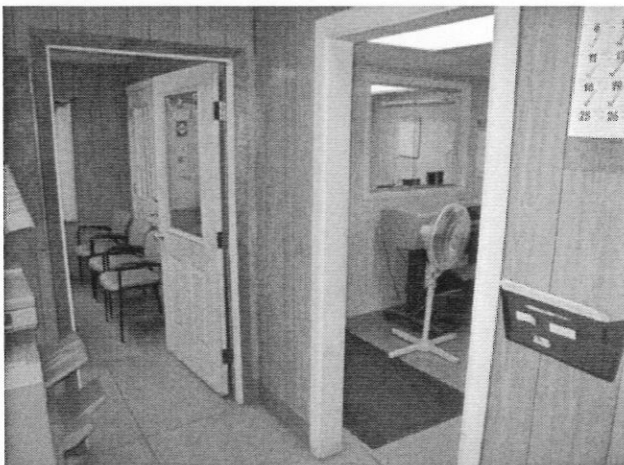

Providence Offices

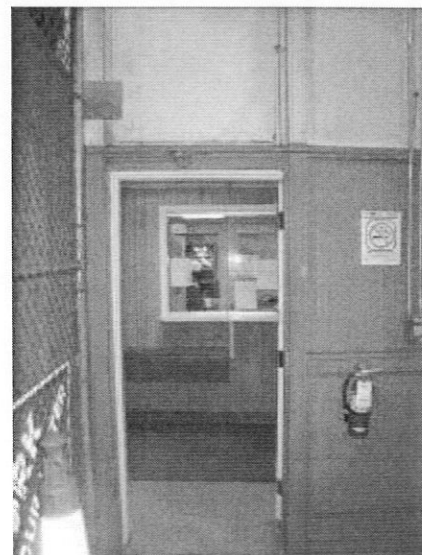

Providence Office Access from Garage

PROVIDENCE (ACADEMY AVENUE) SITE INSPECTION PHOTOGRAPHS



Providence Break Room

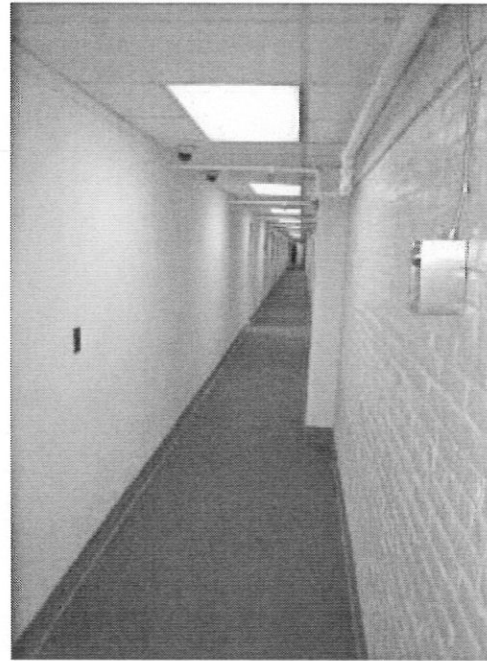

Providence Office Hallway
(Brick Wall Abuts Garage)

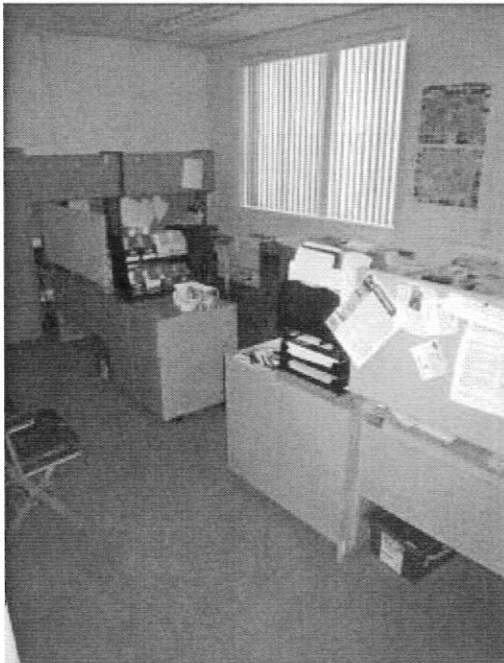

Providence Office Cubicles



Providence Office Mailroom

Appendix C – Sample Questionnaire

PROVIDENCE WATER SUPPLY BOARD

FACILITIES PROGRAMMING QUESTIONNAIRE

April, 2008

This Questionnaire is designed to assist in determining the functional relationships and space needs of the Departments located at PWSB Facilities at Scituate Avenue, Cranston and Academy Avenue, Providence. The following Departments have been identified and requested to complete a separate questionnaire for each functional group within their department.

- A. Administration
- B. Finance
- C. Commercial Services
- D. Engineering
- E. Transportation and Distribution
- F. MIS

1. Name of Department, and functional group.

2. Describe your fundamental mission or purpose.

3. Highlight any significant facilities problems that hinder carrying out your mission.

4. What are your normal working hours? Are there any employees that work outside your normal working hours?

\

5. Do you have any special trash disposal requirements (e.g. security shredder, toxic materials, recyclables materials)?

6. Do you have regular, or at particular times, large deliveries of supplies, equipment or materials? If so, please describe.

7. With what groups do you have the closest functional relationship, that for optimum work flow your work areas should be adjacent to each other? Please describe the kinds of contacts you have with them.

8. With what groups do you have the functional relationship, that for optimum work flow you should be located in the same building or site. Please describe the kinds of contacts you have with them.

9. Would your mission be improved if certain departments or groups were moved from an offsite location to your location, or vice versa. If so, please provide their name and current location.

10. List any other general comments on how your mission could be improved.

PERSONNEL AND SUPPORT FACILITIES REQUIREMENTS:

Department _____ Group _____

1. List below the number of persons employed:

Men _____ Women _____

Persons with disability _____, Describe _____

If working shifts, indicate the number of employees per shift _____

2. Private offices required (Directors and Senior Managers):

Title of employee _____

Size of office _____

Coat closet required _____, or, coat hook on back of door _____

Furniture required: desk&chair _____, reference table _____, side chair _____, file cabinet _____,

bookcase _____, small table _____, computer furniture,

explain _____ other furniture,

explain _____

Locker required _____

Telephone required _____

Data terminal required _____, explain _____

3. Semi-enclosed workstations required (Supervisors and Managers):

Title of employee _____

Size of workstation _____

Access to coat closet required _____, or, coat hook in workstation _____

Furniture required: desk&chair _____, reference table _____, side chair _____, file cabinet _____,

bookcase _____, small table _____, computer furniture,

explain _____ other furniture,

explain _____

Locker required _____

Telephone required _____

4. Workstations in an open area required (Clerical and Support):

Title of employee _____

Workstation description _____

Access to coat closet required _____

Furniture required: desk&chair ____, reference table ____, side chair ____, file cabinet ____, bookcase ____, small table ____, computer furniture, explain _____

other furniture, explain _____

Locker required _____

Telephone required _____

Data terminal required ____, explain _____

5. Employees without a dedicated workstation (Field Workers, Laborers, Equipment Operators, Meter Readers):

Title of employee _____

Number of employees of this type _____

Access to coat closet required _____

Clean/street clothes locker required ____, Dirty clothes locker required ____,

Locker size-12x12x72, 12x12x36, 12x12x12, one or both?

Access to telephone required _____

Access to data terminal required ____, explain _____

6. Visitors reception area required:

Number of visitors to be seated _____

Workstation for receptionist _____,

describe _____

Pass-through window required _____

Walk-up counter required, size _____

7. Conference rooms required:

Number of persons seated, with chairs facing a presentation table _____
Lectern required _____
Number of persons seated at single table _____
Number chalkboard/whiteboard _____, size _____
Tackboard _____, size _____
Projection screen _____
Video tape player _____
Other equipment, explain _____
Telephone _____
Data terminal required _____, explain _____

8. Lunch room required:

Number of persons (from your group) to be seated at one time _____
Food preparation equipment required: sink _____, garbage disposer _____, microwave oven _____,
stove top _____, refrigerator _____, dishwasher _____, compactor _____, dry/canned food
storage cabinets _____, dish/cookware storage cabinets _____
Vending machines required: candy/snack _____, hot beverages _____, cold beverages _____,
other _____
Chalkboard/whiteboard _____, size _____
Tackboard _____, size _____
Telephone _____

9. Employee locker room required:

Number of employees (from your group): men _____, women _____
Clean/street clothes locker required _____, Dirty clothes locker required _____,
Locker size required _____
Shower required (Plumbing Code may require showers) _____
Washfont required _____

Hair dryer required _____
Laundry equipment required _____
Uniform storage required _____

10. Storage rooms required:

Record storage, size _____, file cabinets, number _____, shelving, lineal feet _____,
fire resistant room enclosure required _____

General storage, size _____, Describe use: _____

Other storage room, size _____, Describe use: _____

Other storage room, size _____, Describe use: _____

Other storage room, size _____, Describe use: _____

Share any of the above with other Divisions,
explain _____

11. Miscellaneous rooms required:

Photocopy room, size _____, copier type, size, power requirements _____

recyclables storage required _____

Facsimile equipment room, size _____, equipment requirements _____

Other rooms, explain _____

Share any of the above with other Divisions,
explain _____

SHOP AND VEHICLE FACILITIES REQUIREMENTS:

Department _____ Group _____

1. Employee and Visitor Parking:

Will employee parking be provided on site? Yes _____, No _____, Some _____

If so, how many parking spaces should be provided? _____

Will customer and visitor parking be provided on site? Yes _____, No _____.

If so, how many parking spaces? _____

2. Provide the following information about each required shop space:

Type of shop (for example: carpentry, machine tool, tire, welding, painting, sign, meter testing, automotive) _____

Size required, length x width x

height _____

or bays, length x width x height _____

door size required, width x height _____

truck access required _____

Storage room(s) required, explain _____

shelving size, length required _____

racks required _____

flammable or combustible storage, explain _____

lockable, cage or cabinets _____

truck access required _____

Lift or hoisting equipment required,

explain _____

Special systems required (for example: compressed air, fluids dispensing, waste oil collection, vehicle exhaust, dust collection, closed circuit TV, security, remote control)

Tools required _____

_____ electrical, pneumatic, give requirements _____

Workbench required _____

size, type _____

File cabinets or furniture required _____

Water requirements _____

Floor finish required _____

YARD REQUIREMENTS:

Department _____ Division _____

1. Provide the following information about outdoor bulk storage required:

Bulk material stored (for example - gravel, sand, loam, yard waste, tree cutting waste):

volume stored _____

push wall required _____

Bulk material stored (for example - gravel, sand, loam, yard waste, tree cutting waste):

volume stored _____

push wall required _____

Bulk material stored (for example - gravel, sand, loam, yard waste, tree cutting waste):

volume stored _____

push wall required _____

Bulk material stored (for example - gravel, sand, loam, yard waste, tree cutting waste):

volume stored _____

push wall required _____

Bulk material stored (for example - gravel, sand, loam, yard waste, tree cutting waste):

volume stored _____

push wall required _____

Bulk material stored (for example - gravel, sand, loam, yard waste, tree cutting waste):

volume stored _____
push wall required _____

2. Provide the following information about outdoor container storage:

Container storage (for example - recyclables, yard waste, charitable goods, trash, waste oil, building debris) _____

size of container, length x width x height _____
number of containers _____
public access required _____

Container storage (for example - recyclables, yard waste, charitable goods, trash, waste oil, building debris) _____

size of container, length x width x height _____
number of containers _____
public access required _____

Container storage (for example - recyclables, yard waste, charitable goods, trash, waste oil, building debris) _____

size of container, length x width x height _____
number of containers _____
public access required _____

Container storage (for example - recyclables, yard waste, charitable goods, trash, waste oil, building debris) _____

size of container, length x width x height _____
number of containers _____
public access required _____

Container storage (for example - recyclables, yard waste, charitable goods, trash, waste oil, building debris) _____

size of container, length x width x height _____
number of containers _____
public access required _____

3. Identify material requiring outdoor covered storage:

Covered outdoor storage, explain _____
area required _____
Covered outdoor storage, explain _____
area required _____
Covered outdoor storage, explain _____
area required _____

4. Provide description of spreader storage arrangement required:

size of spreaders _____
number of spreaders _____
rack required _____

5. Outdoor plow storage:

size of plows _____
number of plows _____

6. Describe any other outdoor material storage requirements: _____ :

General outdoor storage required (for example - pipe, hydrants, masonry, curbing, catch basins, manholes), explain _____
area required _____
General outdoor storage required (for example - pipe, hydrants, masonry, curbing, catch basins, manholes),

explain _____

area required _____

General outdoor storage required (for example - pipe, hydrants, masonry, curbing, catch basins, manholes), explain _____

area required _____

General outdoor storage required (for example - pipe, hydrants, masonry, curbing, catch basins, manholes), explain _____

area required _____